

Flow monitor

**DDW-DS31**

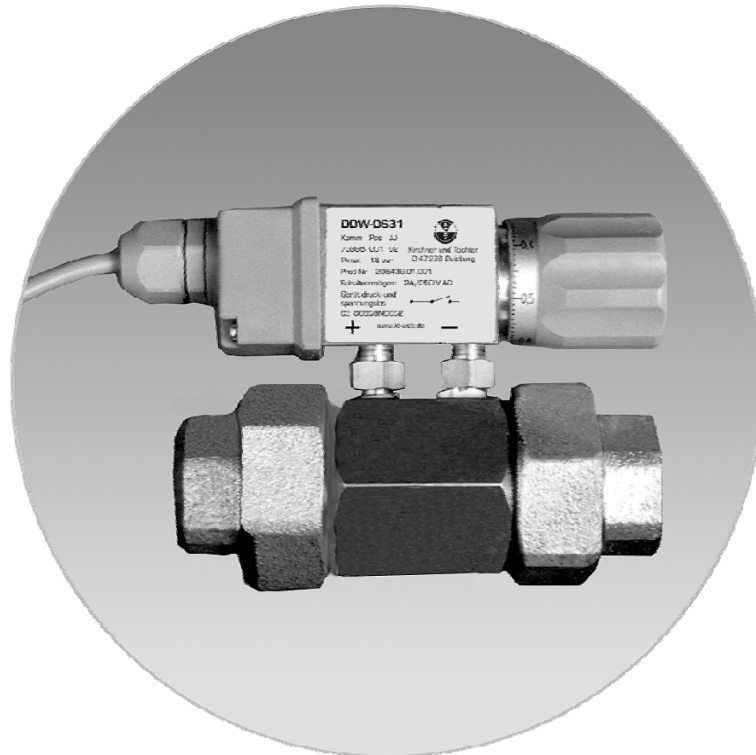

## Installation and Operating Instructions

Flow monitor  
**DDW-DS31-Rp**  
**DDW-DS31-Ga**  
**DDW-DS31-Gi**  
**DDW-DS31-DN**



Kirchner und Tochter

A. Kirchner & Tochter GmbH Dieselstraße 17 · D-47228 Duisburg  
Fon: +49 2065 9609-0 · Fax: +49 2065 9609-22 Internet: [www.kt-web.de](http://www.kt-web.de) · e-mail: [info@kt-web.de](mailto:info@kt-web.de)  
Version 1.2

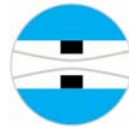

Contents

- 1. Foreword..... 3
- 2. Safety..... 3
  - 2.1. Symbol and meaning..... 3
  - 2.2. General safety directions and exemption from liability..... 3
  - 2.3. Intended use ..... 3
  - 2.4. Operator and operating personnel ..... 3
  - 2.5. Regulations and guidelines ..... 4
  - 2.6. Notice as required by the hazardous materials directive ..... 4
  - 2.7. Transport and storage ..... 4
- 3. Installation ..... 4
  - 3.1. Preparatory work prior to installation ..... 4
  - 3.2. Installing DDW-DS31 with screw connections ..... 5
  - 3.3. DDW-DS31 mounted between flanges ..... 6
  - 3.4. DDW-DS31 with internal thread ..... 7
  - 3.5. Electrical connection..... 8
- 4. Start-up..... 9
  - 4.1. Setting the operating point..... 9
- 5. Maintenance and cleaning of DDW-DS31 ..... 9
- 6. Service ..... 9
  - 6.1. Disposal..... 9
- 7. Technical data ..... 10
  - 7.1. Measuring ranges..... 10
  - 7.2. Dimensions..... 11
  - 7.3. General technical data ..... 14

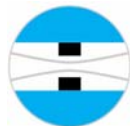

## 1. Foreword

These Installation and Operating Instructions are applicable to devices of Series DDW-DS31. Please follow all instructions and information given for installation, operation, inspection and maintenance. The Instructions form a component part of the device, and should be kept in an appropriate place accessible to the personnel in the vicinity of the location. Where various plant components are operated together, the operating instructions pertaining to the other devices should also be observed.

## 2. Safety

### 2.1. Symbol and meaning



Safety notice

This symbol is placed against all directions/information relating to occupational health and safety in these Installation and Operating Instructions, and draws attention to danger to life and limb. Such notices should be strictly observed.

### 2.2. General safety directions and exemption from liability

This document contains basic instructions for the installation, operation, inspection and maintenance of the flow monitor. Failure to comply with these instructions can lead to hazardous situations for Man and Beast and also to damage to property, for which Kirchner und Tochter disclaims all liability.

The Operator is required to rule out potentially hazardous situations through voltage and released media energy.

### 2.3. Intended use

The DDW-DS31 flow monitor is used for monitoring the flow of water, oils, and neutral fluids. The device operates on the differential-pressure principle. A drop in the differential pressure occurs at a pipe constriction that is proportional to the square of the volume rate of flow through the pipeline. This differential pressure is used to actuate the micro switch. The user sets the switch locally by a hand wheel in the range of the flow span.

### 2.4. Operator and operating personnel

Authorized installation, operating, inspection and maintenance personnel should be suitably qualified for the jobs assigned to them, and should receive appropriate training and instruction.

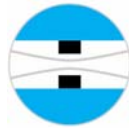

## 2.5. Regulations and guidelines

In addition to the directions given in these Installation and Operating Instructions, observe the regulations, guidelines and standards, such as DIN EN, and, for specific applications, the codes of practice issued by DVGW (gas and water) and VdS (underwriters), or the equivalent national codes, and applicable national accident prevention regulations.

## 2.6. Notice as required by the hazardous materials directive

In accordance with the law concerning handling of waste (critical waste) and the hazardous materials directive (general duty to protect), we would point out that all flow monitors returned to Kirchner und Tochter for repair are required to be free from any and all hazardous substances (alkaline solutions, acids, solvents, etc.).



Make sure that devices are thoroughly rinsed out to neutralize hazardous substances.

## 2.7. Transport and storage

Always use the original packing for transport, handling and storage. Protect the device against rough handling, impact, jolts, etc.

## 3. Installation

### 3.1. Preparatory work prior to installation

Provide the pipe ends at the installation point with the external pipe thread or flanges respectively (Type series DN) appropriate to the device. Make sure the installation space at the installation point is in keeping with the dimensions given in the dimensional drawing and the table in the Technical Data chapter.

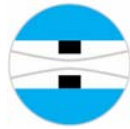

### 3.2. Installing DDW-DS31 with screw connections

The measuring device is screwed into the pipeline between two inserts that are supplied with the device. The straight, unimpeded inlet and outlet runs should be a minimum of 6 x DN upstream and a minimum of 4 x DN downstream of the location. Between the inserts, leave a gap of  $L1 + 4\text{mm}$  for the gaskets. The dimensions for L1 are given on page **Fehler! Textmarke nicht definiert.**

- Cut appropriate threads on the pipe ends (in accordance with the order). Make sure that the ends of the pipe are in alignment.
- Unscrew the union nuts from the DDM-DS11 and slide these on to the pipe ends, with the thread facing towards the device.
- Screw the insert to the pipe ends using suitable packing material.

**Incorrect measurements are possible when device is installed in incorrect mounting position. When installing be aware of the flow direction (see arrow on device (3) or + / - on the flow monitor).**

- Slide the DDM together with the two gaskets (2) between the pipe ends and tighten down the union nuts.

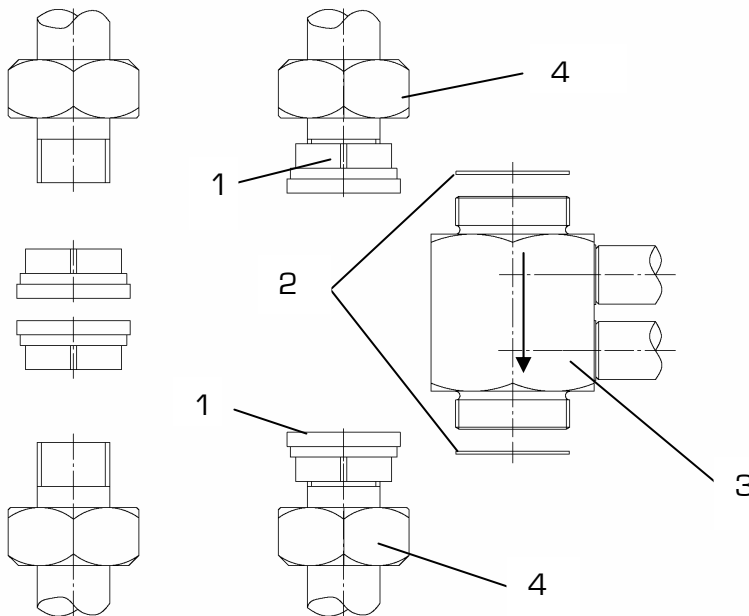

1. Insert
2. Gaskets
3. DDM
4. Union nut

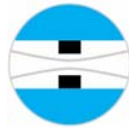

### 3.3. DDW-DS31 mounted between flanges

The flow meter is mounted between flanges to DIN EN 1092-1 (Type 11 or Type 13). The straight, unimpeded pipe run should be a minimum of 6 x DN upstream and a minimum of 4 x DN downstream of the location. The distance between the flanges should be 55 mm for the ring plus twice the thickness of the gaskets to be used. Make sure that the flanges are in alignment and the sealing faces are parallel to each other. Check that the flanges at the location agree with the details given in the order (standard and pressure rating).

- The distance between the flanges should be  $55\text{mm} + 2 \times t$  (thickness of gaskets used).
- Fit half of the screw connections to the interflange connection,
- Mount the orifice, together with the gaskets fitted on both sides, between the two prepared flanges.
- Assemble the remaining screw connections.
- When tightening the screws, make sure that orifice and gaskets are concentric and in alignment with the pipeline.
- Fasten all screw connections uniformly in diagonally opposed sequence.

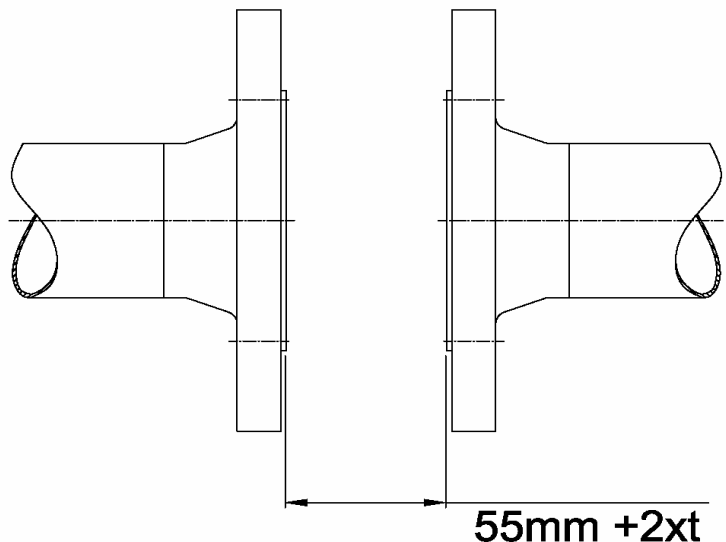
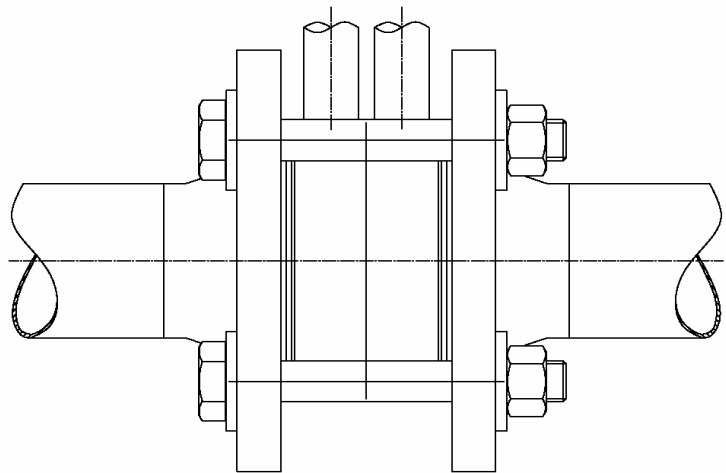

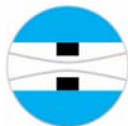

### 3.4. DDW-DS31 with internal thread

As a screw-in pipe fitting, the device is screwed into the pipeline. The straight, unimpeded length of pipe run needs to be a minimum of  $6 \times \text{DN}$  (= nominal diameter) upstream of the installation location and a minimum of  $4 \times \text{DN}$  downstream of the location. Provide a gap of L1 between the pipe ends. The dimension for L1 is given on page 13.

- Provide the pipe ends with suitable threads (in accordance with the order). Make sure that the pipe ends are in alignment.
- Screw the flow indicator to the pipe ends using suitable packing material.
- Be aware of the flow direction (see arrow on device).

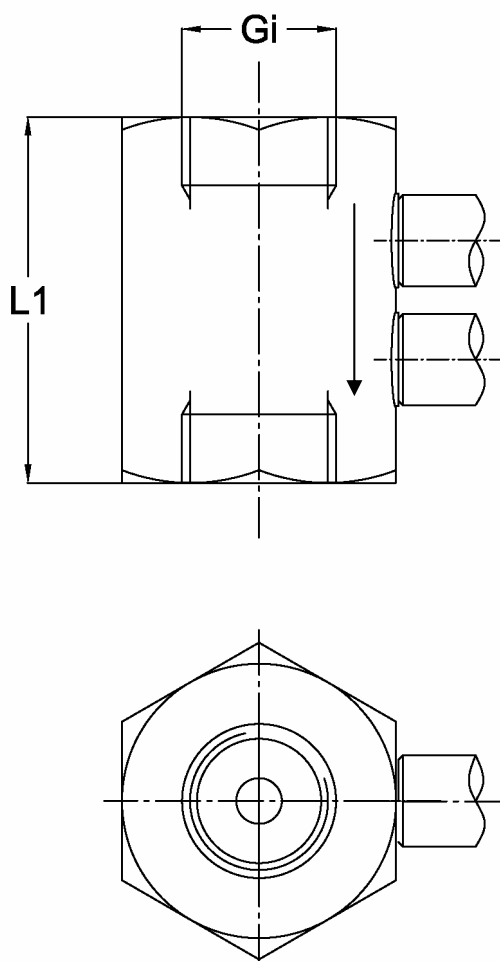

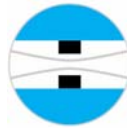

### 3.5. Electrical connection

- Only by authorized and qualified personnel.
- Electrical connection of the device to be carried out in accordance with the relevant regulations of the VDE and the regulations of the local power supply utility.
- Before connecting up the device, disconnect the system from power supply.
- Polarity need not be observed (see diagram).
- Provide protective circuit for the contacts in accordance with the contact rating.
- Demand-adapted fuse elements to be connected on the line side.

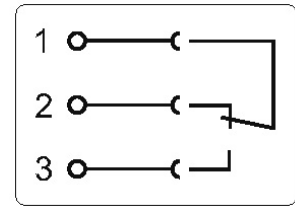

circuit diagram



## 4. Start-up

Before start-up make sure that all electrical supply and switching lines and the measuring orifice have been properly installed. In the case of liquid media, pressure connection lines need to be vented.

- Test all device connections.
- To set the flow: pressurize the pipelines by slowly opening the shut-off valves. On liquid service: carefully evacuate the pipeline.
- Check that all components are leak-tight and, if necessary, tighten down threaded joints and screw connections.
- Where the process medium is water, make sure the device is frost-protected.

### 4.1. Setting the operating point

The required operating point is set by turning the adjusting button. The operating point mark on the rating plate indicates the value set on the scale on the adjusting button.

## 5. Maintenance and cleaning of DDW-DS31

The flow monitor is maintenance-free. To ensure reliable operation and a long service life, we recommend that the device be inspected at regular intervals:

- check of the indicator,
- check of the switching function in connection with follow-on components,
- check of the pressure connection lines between orifice plate and differential pressure switch for leak tightness,
- check of the electrical connection (clamp connection of cables).

Adapt testing and inspection cycles to environmental operating conditions.

## 6. Service

All devices with defects or deficiencies should be sent direct to our repair department. To enable our customer service facility to deal with complaints and repairs as quickly as possible, you are kindly requested to coordinate the return of devices with our sales department, Tel. +49 2065 96 09-0.

### 6.1. Disposal

Please help to protect our environment, and dispose of workpieces in conformity with current regulations or use them for some other practical purpose.

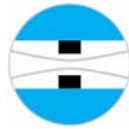

## 7. Technical data

### Materials

Wetted parts	Brass, Al hc, 1.5471, S355J2G3 screw unions: malleable cast iron, galvanized
Diaphragm	Viton, optionally NBR
Gaskets	NBR, optionally Viton

### 7.1. Measuring ranges

#### Measuring ranges for Rp, Gi, Ga

Rp	Volume flow rate (full-scale range) [m <sup>3</sup> /h] H <sub>2</sub> O	
	minimum	maximum
1/4	0,2	1,2
3/8	0,4	2,3
1/2	0,7	4,5
3/4	1,3	8,5
1	2	13,5
1 1/4	3,5	24
1 1/2	5	32
2	7,5	52

#### Connection for in-between flange assembly

DN	Volume flow rate (full-scale range) [m <sup>3</sup> /h] H <sub>2</sub> O	
	Minimum	maximum
50	7	52
65	12	78
80	18	118
100	28	184
125	44	288
150	64	413
200	113	735

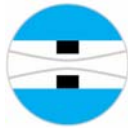

# DDW-DS31

## 7.2. Dimensions

Dimensions DDW-DS31-DN

DN	d4 [mm]	L [mm]	H [mm]
50	102	55	187
65	122	55	197
80	138	55	205
100	158	55	215
125	188	55	230
150	212	55	242
200	268	55	270

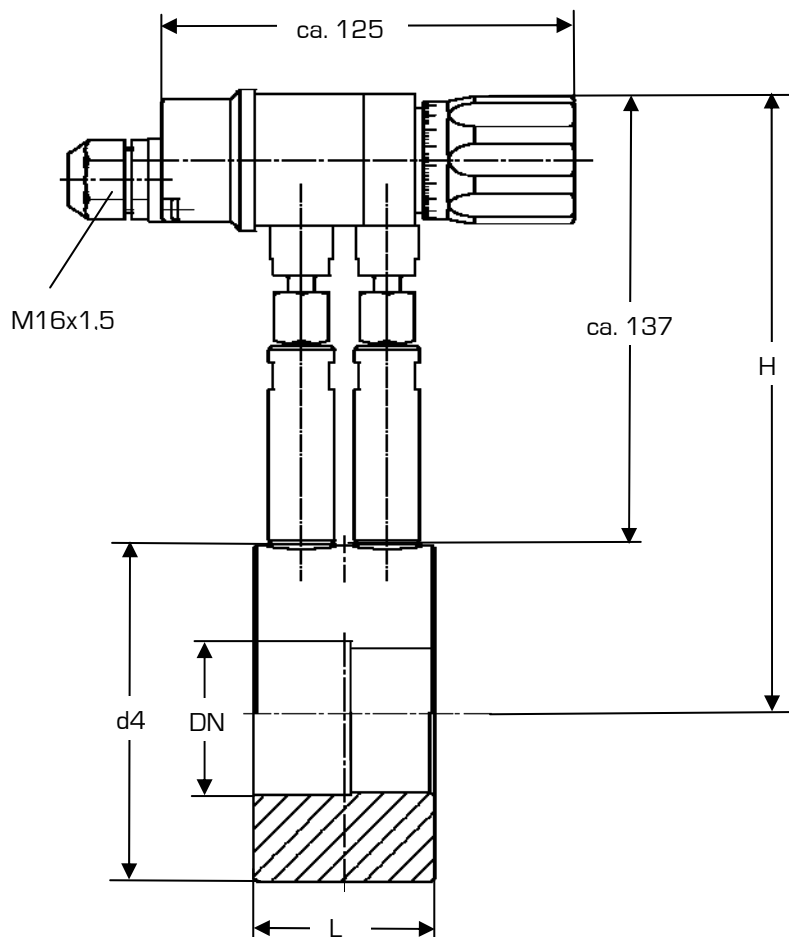

DDW-DS31-DN

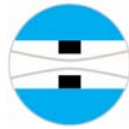

# DDW-DS31

## Dimensions DDW-DS31-Rp

Rp	L1 [mm]	L2 [mm]	SW [mm] (1)	H [mm]
1/4	80	124	41	76
3/8	80	128	46	78
1/2	80	128	46	78
3/4	80	128	50	80
1	80	136	60	85
1 1/4	80	146	70	90
1 1/2	80	149	70	90
2	90	164	85	98

(1) width over flats of hexagonal body

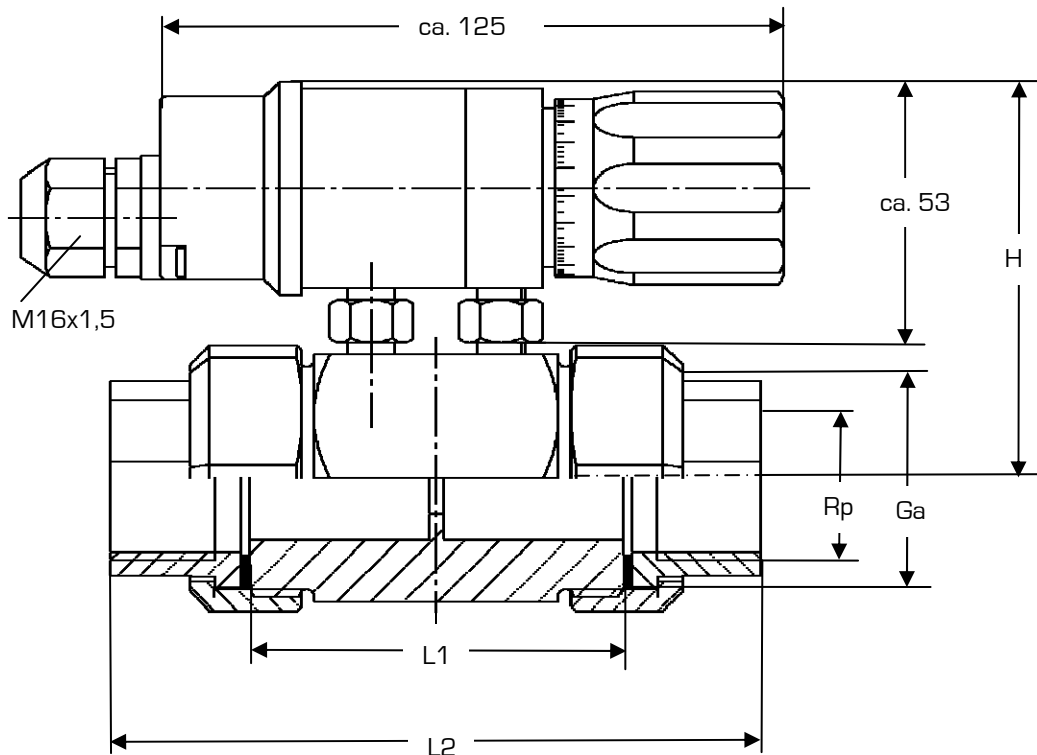

DDW-DS31-Rp/DDW-DS31-Ga

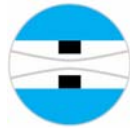

## DDW-DS31

## Dimensions DDW-DS31-Gi/DDW-DS31-Ga (1)

Gi	Ga	L1 [mm]	SW [mm] (2)	H [mm] Gi only
$\frac{1}{4}$	$\frac{3}{4}$	80	41	76
$\frac{3}{8}$	$\frac{3}{4}$	80	46	78
$\frac{1}{2}$	$1 \frac{1}{8}$	80	46	78
$\frac{3}{4}$	$1 \frac{1}{4}$	80	50	80
1	$1 \frac{1}{2}$	80	60	85
$1 \frac{1}{4}$	2	80	70	90
$1 \frac{1}{2}$	$2 \frac{1}{4}$	80	70	90
2	$2 \frac{3}{4}$	90	85	98

(1) Drawing DDW-DS31-Ga: See page 9

(2) width over flats of hexagonal body

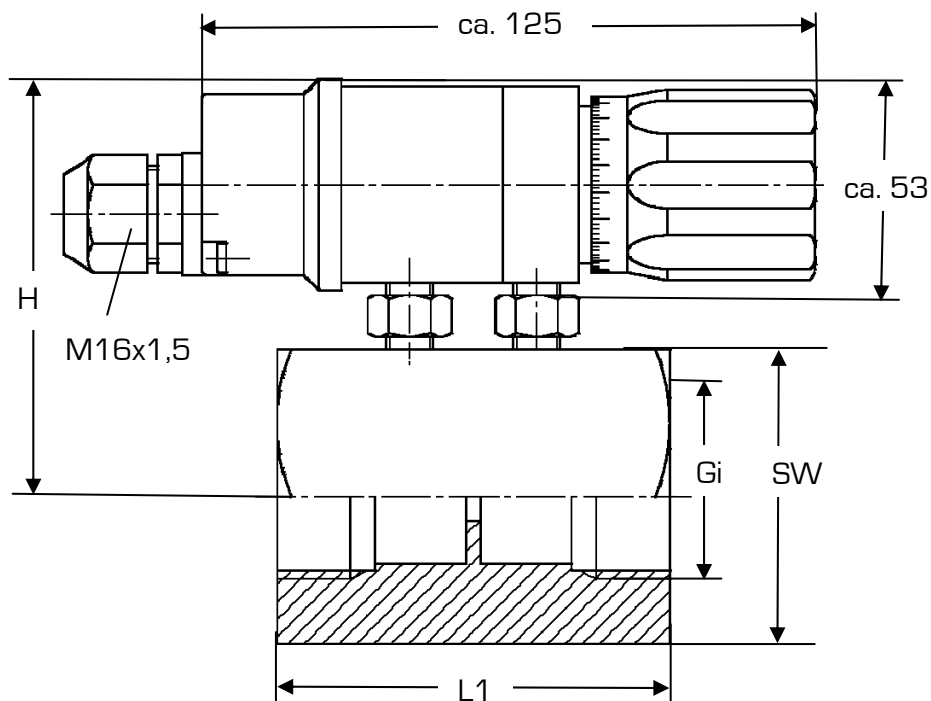

DDW-DS31-Gi

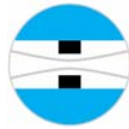

### 7.3. General technical data

Readable setting range	33 % - 100 %	
Monitoring span	1:3	
Process temperature	0 °C... 80 °C (100 °C *)	
Max. stat. operating pressure	16 bar	
Differential pressure	400 mbar or 600 mbar	
Residual pressure loss	approx. 160 mbar or approx. 240 mbar	
Repeatability	5% FS	
Hysteresis	5% at Q-max. 10% at Q-min.	
Switching range	infinitely adjustable in the range of 33-100% of flow rate	
Switching function	N/O contact, optionally N/C contact**	
Type of protection	IP54	
Max. supply voltage	250 V AC	30 V DC
Max. switching current	5 A	0,4 A
Max. contact rating	250 VA	10 W
Electrical connection	permanently installed cable, 2,5 m, optionally angle plug or LED angel plug	
<b>Connection</b>		
Pipe union (Rp)	nut with parallel external fastening screw thread to DIN ISO 228 Part 1, insert with fitting thread to DIN 2999, ISO 7-1	
External thread (Ga)	parallel external fastening screw thread to DIN ISO 228 Part 1.	
Internal thread (Gi)	parallel internal fastening screw thread to DIN ISO 228.	

\* HT- design

\*\* meet the requirements of protection according to the low voltage directive  
73/23/EEC and its modification 93/68/EEC



## DDW-DS31

The equipment from **Kirchner und Tochter** has been tested in compliance with applicable CE-regulations of the European Community.

The respective declaration of conformity is available on request.

Technical data supplied without liability. The current valid version of our documents can be found under this URL: [www.kt-web.de](http://www.kt-web.de)

The **Kirchner und Tochter** QM-System is certified in accordance with DIN-EN-ISO 9001:2008. The quality is systematically adapted to the continuously increasing demands.