



Installation and Operating Instructions

Flap-type Flow Meter KFS

KFS-IK1, KFS-IK2

KFS-RK1, KFS-RK2

KFS-EM

KFS Ex

KFS-IK1 Ex

KFS-EM Ex

For use of the KFS-EM device in hazardous areas, refer to the "Supplementary installation and operating instructions - flap-type flow meter KFS-EM Ex".



Kirchner und Tochter



Contents

1.	General	3
1.1.	Foreword	3
1.2.	Exemption from liability	3
2.	Safety	3
2.1.	Symbol and meaning	3
2.2.	General safety directions	3
2.3.	Intended use	4
2.4.	Information for Operator and operating personnel	4
2.5.	Regulations and directives	4
2.6.	Compliance with the IP degree of protection	4
2.7.	Use of devices of explosion-protected design	4
2.8.	Notice as required by the hazardous materials directive	5
3.	Transport and storage	5
4.	Measuring principle of the flap-type flow meter	5
5.	Installation, start-up and maintenance of the mechanical part	6
5.1.	Preparatory work	6
5.2.	Installation of the KFS	6
5.3.	Start-up	7
5.4.	Maintenance	7
5.4.1.	Compliance with IP degree of protection - KFS with standard indicator part	8
5.4.2.	Setting the reference point - KFS with standard indicator part	8
5.4.3.	Replacement of scale - KFS with standard indicator part	8
5.4.4.	Setting the pointer reference point - KFS-EM	8
5.4.5.	Replacement of scale - KFS-EM	9
5.4.6.	Removal of the indicator part from the pressurized measuring point - KFS-EM	9
6.	Installation, start-up and maintenance of devices with electrical add-on equipment	9
6.1.	Preparatory work for installation and maintenance	9
6.2.	Devices with standard indicator casing	9
6.2.1.	Cabling and setting the switching points of the contacts	9
6.2.2.	KFS-RK1, KFS-RK2	10
6.2.3.	KFS-IK1, KFS-IK2	10
6.2.3.	KFS-IK1, KFS-IK2	11
6.2.4.	KFS-IK1 with ATEX approval	12
6.2.5.	KFS-IKS1, KFS-IKS2	13
6.3.	The indicator part EM	14
6.3.1.	Versions	14
6.3.2.	Electrical signal output KFS-EM	14
6.3.3.	Compliance with IP-degree of protection	14
6.3.4.	Electrical connection KFS-EM	15
6.3.5.	Self monitoring - diagnostics	16
6.3.6.	ESK2A as replacement	16
6.3.7.	Hart™ communication with the ESK2A	18
7.	Service	19
8.	Disposal	19
9.	Technical Data	20
9.1.	General technical data	20
9.2.	Spare parts, accessories	22
9.2.1.	KFS with standard indicator part and contacts IK, IKS or RK	22
9.2.2.	KFS-EM	23
9.3.	Dimensions	24
9.3.1.	KFS Standard	24
9.3.2.	KFS with contact (IK1, IK2, IKS1,....)	25
9.3.3.	KFS-EM	26
9.4.	Type examination certificate for KFS Ex and KFS-IK1 Ex	27
9.5.	Type examination certificate for KFS-EM Ex	28
9.6.	1. Addendum for KFS-EM Ex	29
9.7.	2. Addendum for KFS-EM Ex	30
9.8.	DIN EN ISO 9001:2008	31



1. General

1.1. Foreword

These Installation and Operating Instructions are applicable to devices of Series KFS. Please follow all instructions and information given for installation, operation, inspection and maintenance. The Instructions form a component part of the device, and should be kept in an appropriate place accessible to the personnel in the vicinity of the location. Where various plant components are operated together, the operating instructions pertaining to the other devices should also be observed.

1.2. Exemption from liability

Kirchner und Tochter accepts no liability for any damage or interruptions of operation resulting from human error, failure to comply with these Installation and Operating instructions, improper performance of installation and repair work, use of spare parts other than those from the original manufacturers or use of the KFS devices other than for the intended purpose.

2. Safety

2.1. Symbol and meaning



Safety notice

This safety notice can be found at all hints on work safety in these assembly and operating instructions pointing out hazards for life and limb of persons. Further, this safety notice highlights safety hints in these operating instructions that point to regulations, guidelines or operating sequences that must be observed without fail. Non-observance may result in damages to or a destruction of the flap-type flow meter and / or other parts of the installation.

2.2. General safety directions

These Installation and Operating Instructions contain basic instructions for the installation, operation, inspection and maintenance of the flow meter. Failure to comply with these Instructions or improperly executed installation, wiring and repair work can lead to serious faults in the plant, giving rise to hazardous situations for "man and beast" as well as damage to property.

The operator is required to rule out potentially hazardous situations through voltage and released media energy.



2.3. Intended use

The KFS devices are designed and intended for measuring the flow of compressible and incompressible fluids. They may only be installed between flanges in the pipeline. Select the KFS device model on the basis of the nominal diameter and nominal pressure at the site and also the kind of fluid product concerned; limit values are specified in the Section "Technical data" and should not be exceeded. Only devices that bear the "Ex" marking may be operated in hazardous areas.

2.4. Information for Operator and operating personnel

Authorized installation, operating, inspection and maintenance personnel should be suitably qualified for the jobs assigned to them, and should receive appropriate training and instruction. All persons charged with assembly, mounting, operation, inspection and maintenance duties must have read and understood the operating instructions. Gaskets in contact with the fluid product must be replaced after all maintenance and repair work.

2.5. Regulations and directives



In addition to the regulations mentioned below, pay attention without fail to the notices given in Section 2.7 for operation in hazardous areas!

All relevant regulations should be observed in respect of flow meter operation. These include in particular:

Regulation concerning explosion protection (ExVO National, ATEX 95)
Regulation concerning safe working conditions (Directive 1999/92/EC, ATEX 137)
If appropriate, regulation concerning hazardous materials
Accident prevention regulations
Pressure Equipment Directive PED 97/23 EC

2.6. Compliance with the IP degree of protection

Devices with standard indicator parts have IP66 degree of protection, while the KFS-EM device has IP67 degree of protection. In the case of maintenance work involving the indicator parts, notes on maintaining the IP degree of protection are given in Sections 5.4.1, 6.1 and 0 (KFS-EM).

2.7. Use of devices of explosion-protected design

The KFS, KFS-IK1 and KFS-EM flow meters are certified for use in hazardous areas Zone 1 and 2, device categories 2 and 3, atmosphere G, according to Directive 94/9/EC (ATEX 95). For such use, the regulation concerning electrical and non-electrical devices in hazardous areas (Directive 94/9/EC, ATEX 95) is to be observed.



 For use of the **KFS-EM device in hazardous areas**, refer to the "Supplementary installation and operating instructions - flap-type flow meter KFS-EM Ex". Due to possible static charges, the polycarbonate enclosure of the indicator part of KFS Ex and KFS-IK1 Ex devices may only be cleaned with a damp cloth.

2.8. Notice as required by the hazardous materials directive

In accordance with the law concerning handling of waste (critical waste) and the hazardous materials directive (general duty to protect), we would point out that all flow meters returned to Kirchner und Tochter for repair are required to be free from any and all hazardous substances (alkaline solutions, acids, solvents, etc.).

 Make sure that devices are thoroughly rinsed out to neutralize hazardous substances.

Cavities in the KFS also have to be neutralized. For this purpose, open the neck of the KFS ring by dismantling the indicator (detach the flange connection between the KFS ring and the magnet casing). This includes the screws, Item 9 in the drawing in Section 9.2.1, and Item 15 in the drawing in Section 9.2.2).

3. Transport and storage

The KFS device is packed by the factory in packaging appropriate for transportation and storage. Transport and storage should be carried out solely in the original packaging. Protect the device against rough handling, impact, jolts, etc.

4. Measuring principle of the flap-type flow meter

A half-round plate, or flap, is fastened across the direction of flow to a spring-mounted rotating spindle in a ring that is inserted between flanges in a pipeline. As the flow rate increases, the flap rotates counter to the restoring force of the spring in the direction of flow. The ensuing angle of rotation, depending on the volume rate of flow, is transmitted via a magnetic coupling to the indicator part.



5. Installation, start-up and maintenance of the mechanical part

5.1. Preparatory work

Have ready flanges and fastening materials as specified in DIN EN 1092 for mounting the device between flanges. Between the flanges, include a distance of ring thickness plus

4 mm for the gaskets. Refer to assembly dimensions in Section 9.3.

Check the inside diameter of your pipeline and the gaskets. Neither should be smaller than the inside diameter of the KFS. If they are, the measuring flap will jam. Straight unimpeded pipe runs upstream and downstream of the installation location should have lengths equal to 4-6 times the nominal size DN.

The mounting location for control equipment should be provided downstream of the flow meter.

Make sure that the flanges are in alignment and the sealing faces parallel to one another.

5.2. Installation of the KFS

Generally comply with the maximum pressure and maximum temperature levels allowable for the KFS at the measuring point in your plant.

The direction of flow must be the same as that indicated by the flow arrow on the device.

Drain the pipelines before installing the device.

Use gaskets made of rubber or SIL; for plastics devices, use only gaskets made of rubber with a Shore hardness A of approx. 65°.

The gaskets should not project into the pipeline and the flow meter must be in line with the pipe axis, otherwise measurements would be falsified and/or the device could jam.

Incorporating the indicator part in the equipotential bonding system in the hazardous area: The indicator part must be earthed. This can be done e.g. using a wire jumper between the flange on the indicator part and a pipe flange on the main pipeline with cable lugs appropriate for the bolted connection (not included with the flow meter!). Incorporating the indicator in the lightning protection system (if necessary). The Operator is responsible for checking and determining the scope!

Tighten threaded joints for the KFS made of PVC, PP or PVDF only with max. 75 Nm; higher torques may cause the flap spindle to jam and/or the device ring to break.

The device version made of PVC, PP or PVDF is not allowed to be used in hazardous areas.



5.3. Start-up

Pressurize the measuring pipeline. Avoid water hammer or flow separation, as the case may be. Check the flange connections for leak-tightness and retighten bolted connections if necessary. Test the local indicator on the device with varying volumetric flow rates, starting with the maximum value.

5.4. Maintenance



The device is normally maintenance-free. Should it become soiled, it will need to be removed from the pipeline for cleaning. Devices fitted with contacts must be disconnected from supply and de-energized.

To dismantle the device you will need the following tools: 2x open-jawed spanner, jaw span 13mm, 1x open-jawed spanner, jaw span 7mm, 1x screwdriver 4x 0.6mm, 1x socket spanner, size 7mm, up to DN 100, or 1x socket spanner, size 8mm, up to DN 250, or 1x socket spanner, size 10mm, for DN 300 and higher.

Required spares: 2x gasket

After dismantling, check all parts for signs of damage, corrosion, wear, etc., and replace if necessary!



If necessary, wear personal protective gear (safety goggles, protective gloves, conductive footwear).

Depressurize the pipe.

Caution: Slacken screws/bolts only when the system has been de-energized, the pipe depressurized and free of fluid product.

Drain the pipes.

Remove the device from the pipeline in the reverse order as described in 5.2 .

Detach the dial gauge with magnet casing from the neck of the device by removing the four M8 screws [Item 9 or 15].¹

Unscrew the fastening screws [17] between spindle and flap [18].

Pull the spindle together with the magnet casing and the spring assembly [13] out of the device.

Clean all mechanical parts with appropriate cleaning agents. If necessary, clean the indicator part with a damp cloth that has been rinsed in soap suds and wrung out.

Reassemble in the reverse order, paying special attention to the position of the flap.

The bearing marked with a centre punch must point towards the spring.

Do not change the original orientation of the flap (maintaining the direction of rotation appropriate to the indicator part). The flap requires a minimum of

1 mm clearance on both sides (risk of jamming and sparking).



Hazardous areas: Do not on any account remove the labelling on the scale casing containing information on explosion protection.

¹ For Item nos., see drawings in Section 9.2.1



Before switching on the supply voltage again, make sure that all parts are completely dry and have been connected up in accordance with regulations. Protect the devices from excessive dirt and extreme variations in ambient temperature.



In connection with all maintenance, assembly and repair work of the flow meters, make absolutely sure that a potentially explosive atmosphere cannot occur.

5.4.1. Compliance with IP degree of protection - KFS with standard indicator part



When carrying out assembly work on the indicators (KFS, KFS-IK1, KFS-IK2, KFS-IKS1, KFS-IKS2, KFS-RK1, KFS-RK2), and to comply with the IP degree of protection, you should wear rubber gloves or similar expedient in order to obtain a maximum torque when tightening the bayonet joint.

5.4.2. Setting the reference point - KFS with standard indicator part

If, when flow is switched off, the pointer in the indicator part should not be located at the reference point, correct the reference point setting. Make all adjustments only after the flow has been switched off.

You will need the following tools: open-jawed spanner, jaw span 7mm, screwdriver 4x 0.6mm. Detach the bayonet ring (1)¹ from the pressure gauge casing and remove it together with the seal (3) and perspex disc (2).

Lock the pointer spindle using the 7 mm open-jawed spanner, unscrew the fastening screw (4) and reset the pointer to the reference point.

Reassemble the indicator in reverse order.

5.4.3. Replacement of scale - KFS with standard indicator part

You will need the following tools: open-jawed spanner, jaw span 7mm, screwdriver 4x 0.6mm,

socket spanner, span 5.5mm; if necessary, 1 spring washer (5)².

Detach the bayonet ring (1) from the pressure gauge casing and remove it together with the seal (3) and the perspex disc (2).

Lock the pointer spindle using the 7 mm open-jawed spanner, and unscrew the fastening screw (4) and the spring washer (5).

Remove the pointer (6).

Unscrew the three cap nuts (7) and remove the scale (12) from the casing.

To fit the new scale, proceed in the reverse order.

5.4.4. Setting the pointer reference point - KFS-EM

Tools needed: 1x flat-tip screwdriver

Undo the four slotted screws in the corners of the casing cover and remove the cover.

With the flat-tip screwdriver, hold the pointer spindle in the "at rest" position of the indicator part and use your other hand to move the pointer against the frictional force of the pointer fastening to the point on the scale marked "Rp".

Fasten the casing cover with the four slotted screws.

² For Item nos., refer to drawings in Section 9.2.1



5.4.5. Replacement of scale - KFS-EM

Tools needed: flat-tip screwdriver

Undo the four slotted screws in the corners of the casing cover and remove the cover.

The scale is located in 2 slots in the surrounding casing. Pull the scale sideways out of these slots in the direction of the pointer.

Insert the new scale.

Fasten the casing cover with the four slotted screws.

5.4.6. Removal of the indicator part from the pressurized measuring point - KFS-EM

Detach the indicator part at the two brackets on the outside of the indicator casing (see note in Section 9.2.2).

6. Installation, start-up and maintenance of devices with electrical add-on equipment

are described in Section O.

Installation and wiring work may only be carried out by qualified electricians. In respect of hazardous-duty equipment, the following installation standards must be observed:

EN 60079-14

EN 60079-17

6.1. Preparatory work for installation and maintenance

For connecting the contacts, have ready flat-tip and crosshead screwdrivers as well as tools for stripping the cables and cutting them to size. In keeping with the electrical specifications of your device, you will in addition need cable material for the connection. To maintain the IP degree of protection, only cables with outside diameters of 4.5mm - 7mm may be used in connection with the right-angle plug at the standard indicators with contacts [KFS IK1,..]. The cable specifications for the KFS-EM device are given in Section O for indicator part EM.

6.2. Devices with standard indicator casing

This includes the following devices: KFS-IK1, KFS-IK1 Ex, KFS-IK2, KFS-IKS1, KFS-IKS2, KFS-RK1 and KFS-RK2. The casing consists of a tall Polycarbonate cover, a bayonet ring and appropriate casing, and a gasket (note: IP degree of protection! Refer to Section 5.4.1). Only the KFS-IK1 Ex device may be used in the hazardous area.

6.2.1. Cabling and setting the switching points of the contacts

Disconnect the cable from the mains.

Remove the right-angle plug from the rear panel of the indicator.



Take the plug out of the connector housing and detach the PG screwed cable gland elements.

Slide the individual parts of the PG screwed cable gland and the housing of the right-angle plug over the cable.

Strip the insulation from the wires and connect these to the right-angle plug according to the terminal diagrams in the following sections.

Remount the right-angle plug in the casing and tighten down the PG screwed cable gland.

Connect to mains.

The contact switching points are easy to adjust after removing the perspex hood.

Use a finger to move the setpoint pointer of the switch to the appropriate point on the scale. Then check the switching point by moving the pointer beyond the set switching point.

6.2.2. KFS-RK1, KFS-RK2

The series RK signal transmitters are mechanically operating, floating reed contacts. We advise using switch protection relays of the MSR series to increase the switching capacity and reduce the capacitive load. These are available in various versions in terms of voltage supply, sensor output and number of outputs.

RK1	Version with one switch
RK2	Version with two contacts
Contact	Reed Contact, floating
Switching function	NC / NO
Switching performance	Bistable
Voltage switched	max. 140 V AC / 200 V DC
Current switched	max. 0.25 A
Contact rating	max. 5 VA, 3 W
Ambient temperature	-25° C ... + 105° C

Terminal assignment for reed contacts

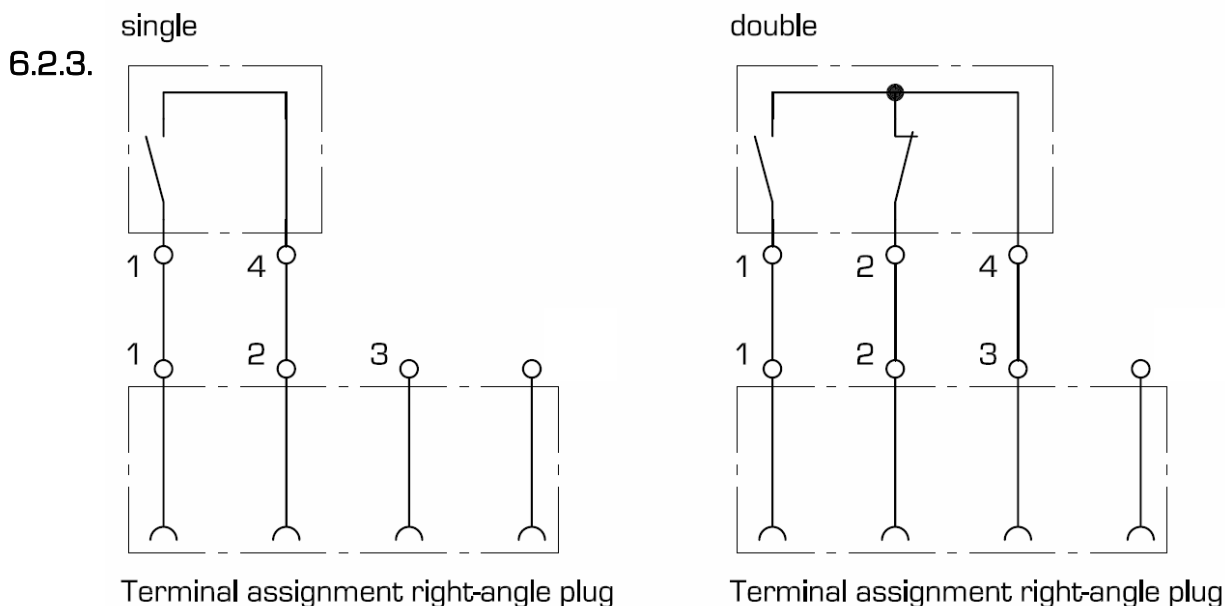



KFS-IK1, KFS-IK2

Series IK built-in electrical signal transmitters are non-contacting, inductive make and break contacts which operate when a control vane moved by the setpoint pointer dips into and out of the slot initiator. The change in signal is used for driving a control device via an isolation switching amplifier.

IK1	Version with one Contact
IK2	Version with two contacts
Contact data	
Function	Inductive slot initiator to NAMUR DIN 19233, two-wire
Switching function	NC or NO contact
Slot width	2.0 mm
Hysteresis	1.0% of FS ... 10.0% of FS
Repeat accuracy	≤ 2.0%
Temperature drift	≤ 10%
Ambient temperature	-25°C ... + 70°C
Voltage	nom. 8.2 VDC
Switching frequency	≤ 2.5 kHz
Switching performance	bistable
Nominal voltage	8 V DC via isolation switching amplifier KFA
Power consumption	
active area uncovered	≥ 2.1 mA
active area covered	≤ 1.2 mA
Ambient temperature	-25°C ... +70°C
Polarity reversal protection	yes
Certification to	KEMA 01 ATEX 1264X
Inner inductance [Li] / capacitance [Ci]	41 nF / 266 μH values for cable assemblies up to 10m
	II 1 G Ex ia IIC T6
Contact marking	(max. U _i = 15V, I _i = 60mA, P _i = 100mW)

Terminal assignment contact IK1

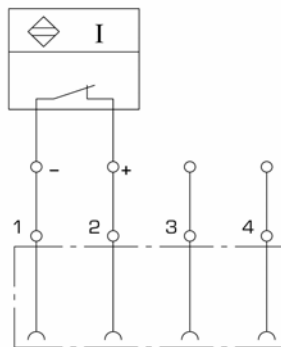

Terminal assignment right-angle plug

Terminal assignment contact IK2

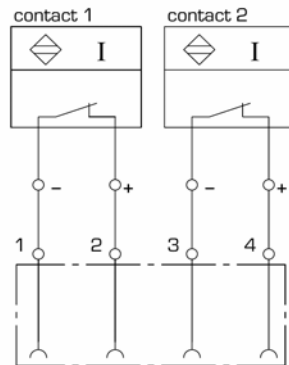

Terminal assignment right-angle plug



6.2.4. KFS-IK1 with ATEX approval

The Operator is required, as a matter of principle, to take note of the details given in the type examination certificate (TÜV ATEX 7041 X). The contact IK1 operates on the same principle as the above-mentioned signal transmitter. Devices with this contact satisfy the requirements of Directive 94/9/EC (Atex 95) and are permitted to be operated in Zone 1 hazardous areas, provided they are fed from a certified and matched intrinsically safe circuit. The allowable electrical connection data and maximum allowable ambient temperatures for operation in hazardous areas are contained in the EC-type examination certificates for Category 2G ia IIC T4..T6. For use in hazardous areas, the following measures must be taken:

 The indicator part must be earthed. This can be done, e.g. by using a wire jumper between the flange on the indicator part and a pipe flange on the main pipeline with cable lugs appropriate for the bolted connection (not included with the flow meter!).

Use isolation switching amplifiers with appropriate type test certificates to ATEX. Suitable switching amplifiers are:

KFA6-SR2-Ex1.W, supply power 230 VAC

KFA5-SR2-Ex1.W, supply power 115 VAC

KFD2-SR2-Ex1.W, supply power 24 VDC

 The bolted connections of the flanges between indicator part and flap must feature tooth lock washers on both sides. These are already mounted on delivery.

The devices approved for hazardous duty feature a blue PG screwed gland at the right-angle plug for the indicator part, with integrated strain relief device.

In addition, a sticker is located on the indicator with information on how to avoid electrostatic charges.

Allowable media temperatures:

 -20°C ... +70°C without additional insulation measures
-70°C +200°C when Operator has insulated measuring part and pipe to prevent heat up of indicator part and el. components



6.2.5. KFS-IKS1, KFS-IKS2

Built-in electrical signal transmitters of the IKS series are non-contacting make and break contacts which operate when a control vane actuated by the setpoint pointer dips into and out of the slot initiator. The signal change can be processed directly in a PLC system.

IKS1	Version with one contact
IKS2	Version with two contacts
Contact	Inductive slot initiator
Switching function	NC or NO
Switching performance	bistable
Supply voltage	24 V DC
Current switched I_A	100 mA
Open-circuit power consumption	10 mA
Ambient temperature	- 25° C ... + 70° C
Explosion protection	no
Voltage drop (at I_{max})	1.2 V

Note:

Given PNP-switching devices, the switched output 3 forms a connection to 2 (+). Between 3 and 1 a load R_L must be selected so that the max. current switched (100 mA) is not exceeded. For two contacts, this applies analogously to a load R_L between 1 und 4 [no direct connection between 1 and 3, or 1 and 4].

Terminal assignment contact IKS1

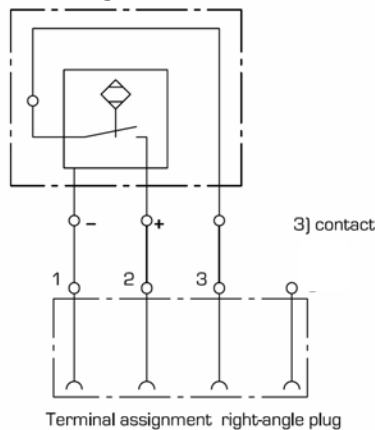

Terminal assignment contact IKS2

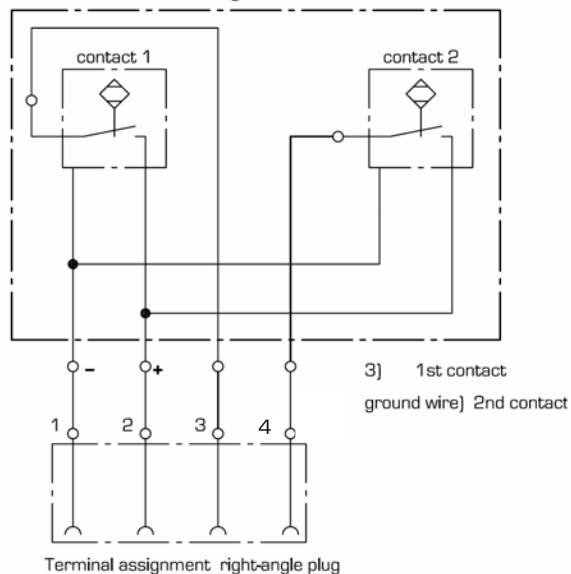



6.3. The indicator part EM

6.3.1. Versions

KFS-EM	with electronic transmitter ESK2A 4...20 mA in 2-wire technology
KFS-EM Ex	with electronic transmitter ESK2A 4...20 mA in 2-wire technology explosion-protected equipment to European Standard



Note: For use in hazardous areas, please refer to the "Supplementary Installation and Operating Instructions - flap-type flow meter KFS-EM EEx".

6.3.2. Electrical signal output KFS-EM

The indicator part of the KFS-EM with the ESKII module supplies a current of 4 to 20 mA in two-wire connection that is proportional to the instantaneous flow rate. Transmission is force-free and hysteresis-free. The ESK2A has been factory-calibrated relative to the flow measuring range. The calibration values, used for linearization of the indicator, are stored in a memory chip (EEPROM). The required power supply is a functional extra-low voltage with safety separation (galvanic) in accordance with VDE 0100 Part 410.

All instruments connected to the measuring circuit (indicators, recorders) are connected in series and together may not exceed the maximum external resistance (see data pertaining to electrical signal output). The ESK2A has polarity reversal protection.

6.3.3. Compliance with IP-degree of protection

To comply with the IP degree of protection for built-in electrical equipment, please pay attention to the following:

After inserting the connecting cable, tighten the cap nut on the cable gland.

Close off all cable glands not used with blanking plugs .

Do not kink cables directly at the cable gland.

Provide a water drip point

Ensure incoming cables are not subjected to mechanical loads.

Cable glands / screwed glands:

Thread	Material	Cable diameter	Protection*	Comment
M 16x1.5	PA	5 - 10 mm	IP 68 - 5 bar	Standard
M 20x1.5	PA	8 - 13 mm	IP 68 - 5 bar	
M 16x1.5	brass, nickel-pl.	5 - 9 mm	IP 68 - 5 bar	
M 20x1.5	brass, nickel-pl.	10 - 14 mm	IP 68 - 10 bar	

* degree of protection restricted to cable gland only



6.3.4. Electrical connection KFS-EM

The connection terminals of the ESK2A module in the KFS-EM indicator part are of the plug-in type and can be removed to connect the cables.

Terminal connection
Type of connection

pluggable; $\leq 2,5 \text{ mm}^2$
 2 wire current sink - polarity reversal protection
 only for connection to extra-low voltage according
 to SELV or PELV

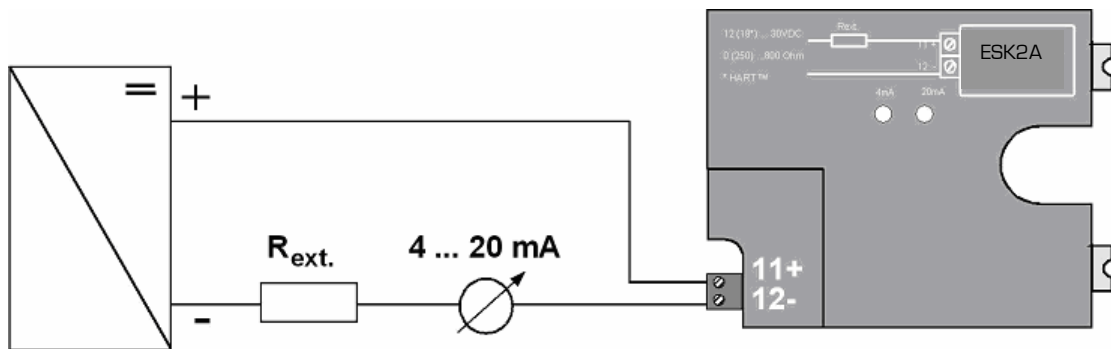

Be careful by conceptual design in connection with other instruments (e.g. supply units or process control engineering).
 It is possible that internal connection of ground, earth-connections or equipotential bonding will generate voltage drops, which leads to malfunction of the instrument. For this case a signal processor is required.

Connections at hazardous locations

Before installation at hazardous location read the Supplementary Installation and Operating Instruction.



Technical data ESK2A

Power supply	24 V DC 4 to 20 mA for 0 to
Measuring signal	100% flow value > 20.8 mA for alarm status
Supply power influence	< 0.1%
Ext. resistance dependence	< 0.1%
Temperature influence	< 5 μ A / K
max. external resistance / load impedance	0 [250 *] to 800 ohm
Ambient temperature	-25°C ... + 60°C

* With HART™ communication, these are **minimum** values.

6.3.5. Self monitoring - diagnostics

Setting-up operation as well as operation there are several cyclic diagnostic functions to get operational reliability. An error detection generates an output signal (high) of ≥ 21 mA.

Additional information are given via HART™ command #48. Information and warnings will not generate an error output current.

Diagnostic functions (control):

- Plausibility of FRAM data
- Plausibility of ROM data
- Working range of internal reference voltages
- Signal detection of the measuring range of the magnet sensors
- Temperature compensation of the magnet sensors
- Calibration corresponding the application
- Plausibility of counting value
- Plausibility of physical unit and selected unit

6.3.6. ESK2A as replacement

The ESK2A has been normalized by the factory so that, for example, replacement can be carried out without recalibration. If necessary, the zero and the 100% value can be readjusted.

In that case, loss of accuracy is to be expected [Class 1.6 \rightarrow Class 2.5].



Installing an ESK2A

Assembly is based on the plug-in technique. Insert the push-in lugs of the ESK2A under the two studs of the baseplate (1).

Using slight pressure, press the ESK2A on to the spring bolt (2) until it locks home and is securely fastened.

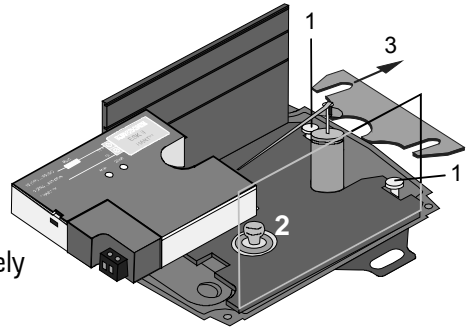

Replacement of an ESK2A

The new ESK2A needs to be recalibrated if compliance with the accuracy class is required. Without recalibration, loss of accuracy has to be expected (Class 1.6 → Class 2.5).

The calibration data are stored in the memory chip. De-energize the ESK2A.

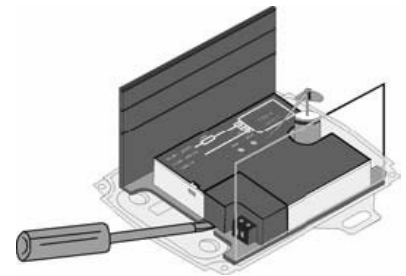

Setting the zero and 100% value on the ESK2A

The zero and 100% value can be set by means of built-in pushbuttons. If the button behind the "4" is pressed for longer than 5 seconds, the measured value will skip to 4mA. The ESK2A is then in the zero adjustment mode. Optionally, press button "4" for downward correction or button "20" for upward correction, until zero amounts to exactly 4.00mA.

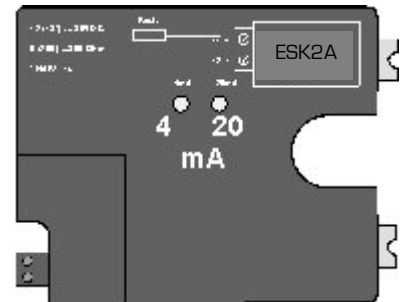

In the same way, the 100% value can be set if pushbutton "20" is held pressed for more than 5 seconds.

If no button is pressed for a duration of 10 seconds, the ESK2A goes automatically to its measuring mode and includes the corrections. These corrections are stored and remain valid even when the ESK2A is switched off. These settings have no effect on the linearity of the measurement.



6.3.7. Hart™ communication with the ESK2A

HART™ communication is not obligatory in order to operate the ESK2A. If HART™ communication is carried out with the EM, it will in no way affect analog data transmission (4...20mA)... HART™ Protokoll Revision 5.9

Exception: with multidrop operation. In multidrop operation, a maximum of 15 devices with HART™ function can be operated in parallel, their current outputs being switched to the inactive state (approx. 4mA).

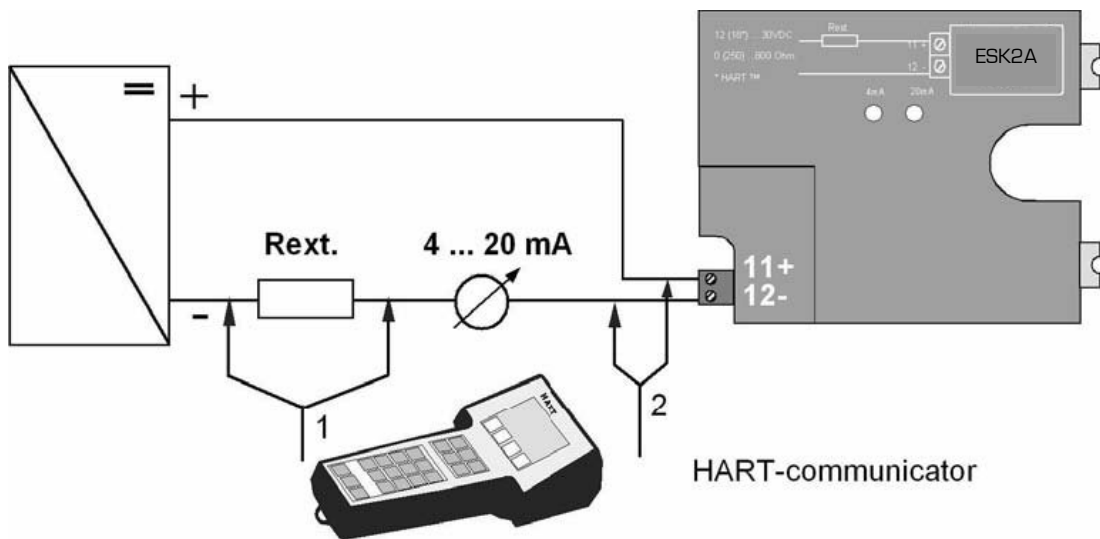

Where a HART™ communicator (Type Fisher Rosemount, Model 275) or a PC with HART™ modem is used, the series-connected resistance (Rext.) must be greater than 250 Ohm. The supply power must be at least 18 Volt. The communicator or PC is connected up as shown in the above drawing.

It can optionally be operated via the power terminals of the ESK2A (2) or via a series-connected external resistance (1).

If the ESK2A is operated in conjunction with the meter, HART™ communication is possible according to the following wiring diagram:

The meter itself cannot be read or operated by means of the HART™ communication!

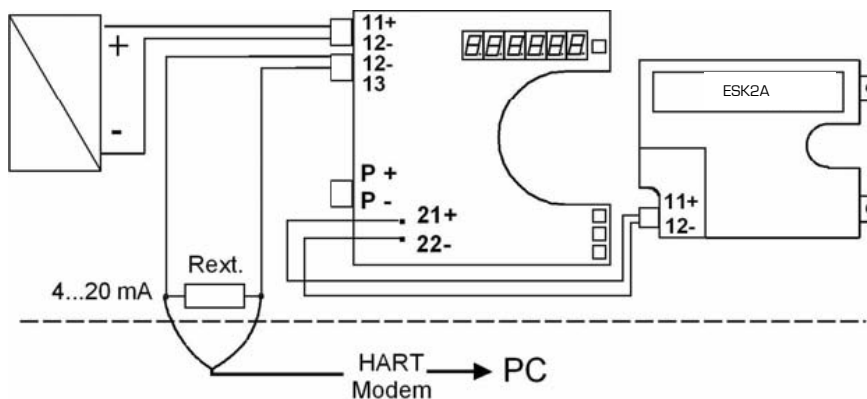



7. Service

All devices with defects or deficiencies should be sent direct to our repair department. To enable our customer service facility to deal with complaints and repairs as quickly as possible, you are kindly requested to coordinate the return of devices with our sales department, Tel. +49 (0) 2065-96090.

Please also follow the instructions given in Section 2.5.

When ordering spare parts, please remember to quote the parts number as listed in the bill of materials and the order number of the component given on the rating plate.

8. Disposal

Please help to protect our environment, and dispose of workpieces in conformity with current regulations or use them for some other purpose.



9. Technical Data

9.1. General technical data

Measuring accuracy	5% FS
Scale	in physical units, e.g.: l/h, m ³ /h
Length of scale	max. 95 mm
Turndown ratio	min. 1 : 10
Degree of protection, indicator part	IP 66 (IP 67 for KFS-EM)
Corrosion protection for steel version	Epoxy paint, kiln-dried, traffic blue, RAL 5017 satin-finished, corrosion class: C2
Steel/stainless steel version¹⁾	
Process temperature	- 70°C ... + 200°C PN 6/10 - 20°C ... + 70°C PN 6/10 (KFS Ex and KFS-IK1 Ex) ²⁾
Allowable operating pressure	PN 6/10
Optionally	PN 16/25/40
PVC version ¹⁾ (not suitable for hazardous areas)	
Process temperature	0°C ... + 20°C at 10 bar 0°C ... + 40°C at 6 bar
Allowable operating pressure	PN 6/10
PP version ¹⁾ (not suitable for hazardous areas)	
Product temperature	0°C ... + 20°C at 10 bar 0°C ... + 80°C at 1.5 bar
Allowable operating pressure	PN 6/10
PVDF version ¹⁾ (not suitable for hazardous areas)	
Product temperature	- 40°C ... + 20°C at 10 bar - 40°C ... + 140°C at 2 bar
Allowable operating pressure	PN 6/10
Mounting length	Standard: 50 mm Special spring: 60mm
Connections optionally	Mounting between welding neck flanges to DIN EN 1092 acc. to ANSI 150 lbs, JIS 150 lbs, others on request

¹⁾ The process fluid must not freeze

²⁾ Where insulation measures have been carried out to pipeline and measuring part, 70°C ... + 200°C are also possible



Materials

Material, ring	Wetted internals	Wetted gasket ²⁾	DN
Steel	1.4571	Sil 4400	25-600
Stainless steel 1.4571	1.4571	Sil 8200	25-600
PVC	1.4571 ¹⁾	EPDM	25-300
PP	1.4571 ¹⁾	EPDM	25-300
PVDF	1.4571 ¹⁾	Viton	25-300
Indicator part	KFS	KFS-EM	
Scale casing	Stainless steel 1.4301	Aluminium, painted	
Pointer	Aluminium, painted	Aluminium, painted	
Scale	Aluminium, coated	Aluminium, coated	
Pane	PC, optionally glass	Float glass	

¹⁾ optionally Hastelloy C4

²⁾ others on request

Rubber coating on request

Hazardous-duty versions only available for materials: Steel and Stainless Steel 1.4571



9.2. Spare parts, accessories

9.2.1. KFS with standard indicator part and contacts IK, IKS or RK

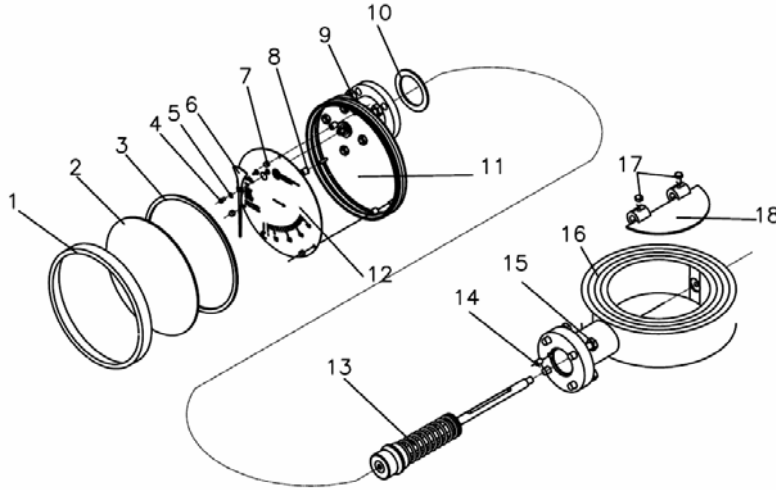

KFS with standard indicator part

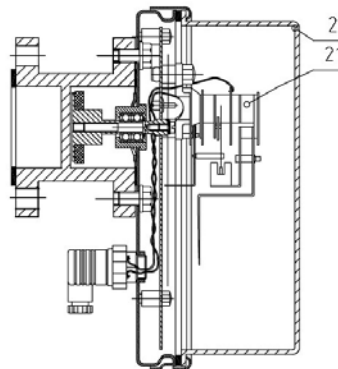
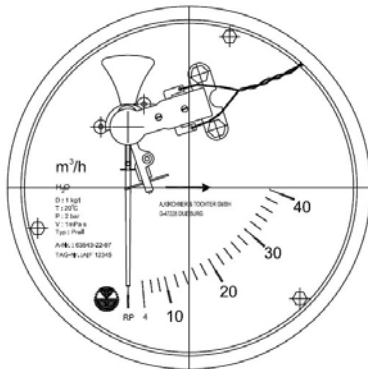

Indicator KFS-IK/IKS/RK

Item	Qty	Description
1	1	Bayonet ring
2	1	Perspex cover
3	1	Sealing ring
4	1	Screw M3
5	1	Spring washer
6	1	Pointer
7	3	Cap nut M3
8	3	Separator
9	4	Nut M8
10	1	Gasket

Item	Qty	Description
11	1	Bayonet casing
12	1	Scale
13	1	Spindle with magnet and spring
14	1	Alignment pin
15	4	Screw M8
16	1	Ring
17	1-2	Screws
18	1	Flap
19	8	Tooth lock washer DIN 6797-A8.4-A2 (KFS-IK1 only, ATEX version)
20	1	Sticker for ATEX version: reference to electro- static charges (KFS-IK1 only, ATEX vers.)
21	1	Contact of device used: IK1, RK1,..



9.2.2. KFSE-EM

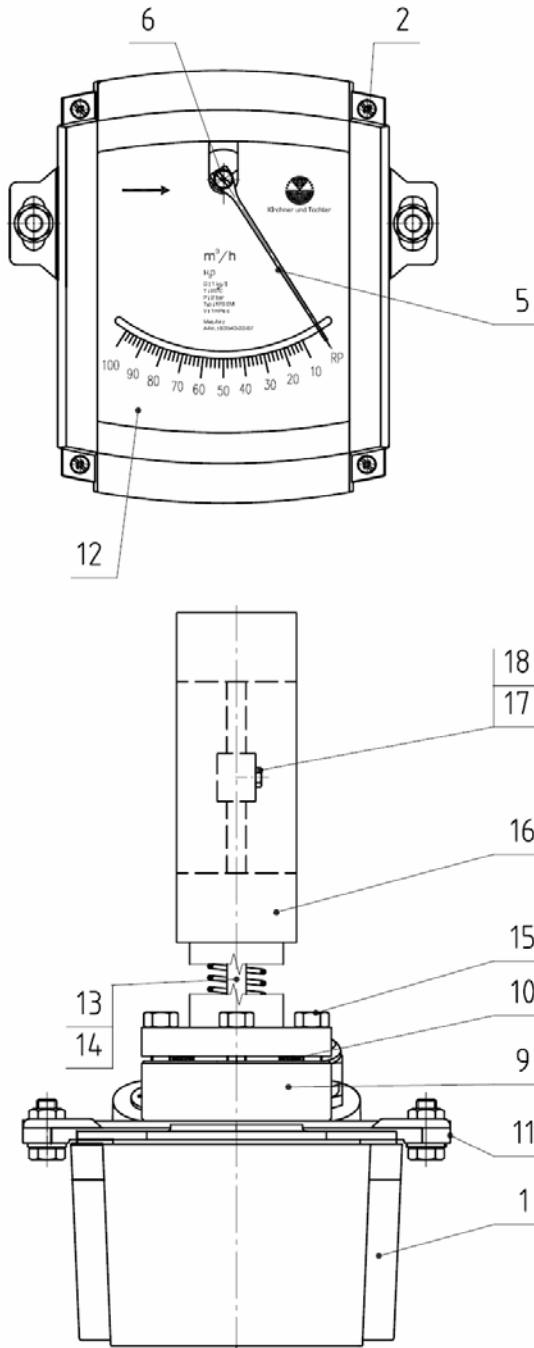

Item	Qty	Description
1	1	Cover [transparent]
2	4	Slotted screw
5	1	Pointer
6	1	Pointer spindle
9	1	Magnet casing
10	1	Gasket
11	1	Rear panel
12	1	Scale with rating plate
13	1	Spindle with magnet and spring
14	1	Alignment pin
15	4	Screw M8
16	1	Ring
17	1-2	Screws
18	1	Flap

Note: To dismantle indicator part when measuring part pressurized: remove screws from Item 11.



9.3. Dimensions

9.3.1. KFS Standard

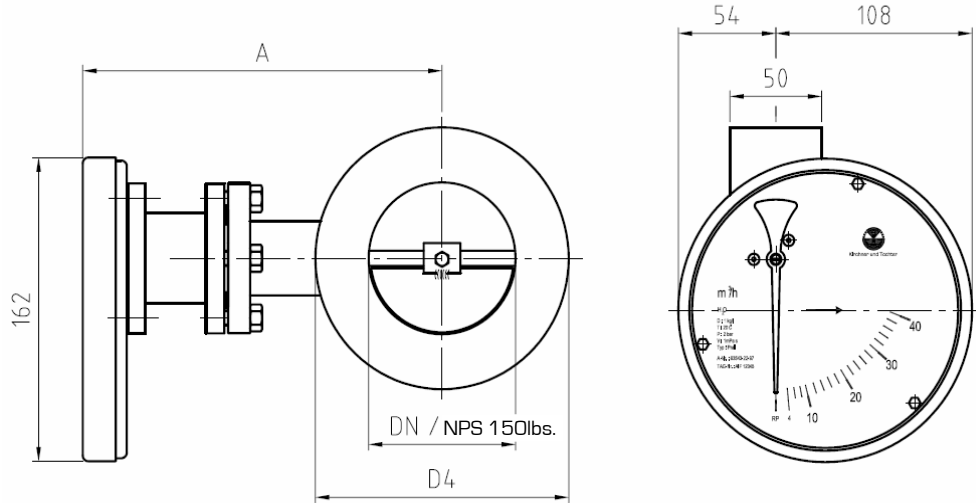

Note: The flap axis for DN32 and DN25 devices is located 9mm above the ring axis! NPS = Nominal pipe size acc. to ANSI / ASTM

DN	d4	A1)	Weight [kg]		NPS	d4	A1)
			Steel	PVC			
25	68	202	3.8	2.0	1"	51	199
32	78	206	3.8	2.0	1 1/4"	64	204
40	88	206	3.8	2.0	1 1/2"	73	206
50	102	211	3.9	2.1	2"	92	212
65	122	219	5.0	2.3	2 1/2"	105	217
80	138	226	5.6	2.5	3"	127	225
100	158	236	6.4	2.7	4"	157	237
125	188	249	8.0	2.8	5"	186	250
150	212	261	8.8	3.3	6"	216	263
200	268	286	11.4	3.7	8"	270	287
250	320	311	13.0	4.5	10"	324	313
300	370	336	22.0	4.9	12"	381	338
350	430	376	29.3	-			
400	482	401	31.5	-			
500	585	451	39.0	-			
600	685	501	45.5	-			

All dimensions in mm

1) The PVC / PP / PVDF versions deviate in part from the standard.



9.3.2. KFS with contact (IK1, IK2, IKS1,....)

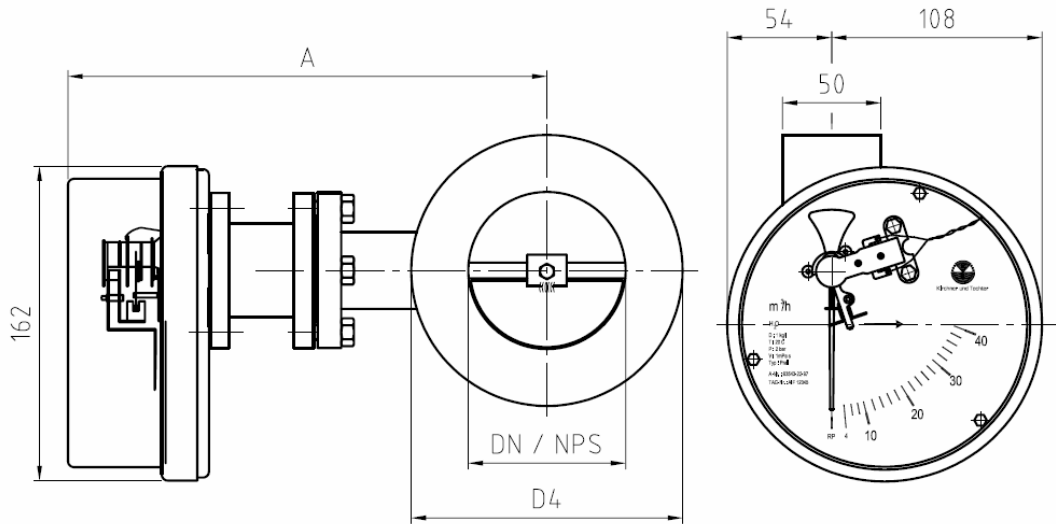

Note: The flap axis for DN32 and DN25 devices is located 9 mm above the ring axis! NPS = Nominal pipe size acc. to ANSI / ASTM

DN	d _s	A ¹⁾	Weight [kg]		NPS	d4	A ¹⁾
			Steel	PVC			
25	68	249	3.8	2.0	1"	51	246
32	78	253	3.8	2.0	1 1/4"	64	251
40	88	253	3.8	2.0	1 1/2"	73	253
50	102	258	3.9	2.1	2"	92	259
65	122	266	5.0	2.3	2 1/2"	105	264
80	138	273	5.6	2.5	3"	127	272
100	158	283	6.4	2.7	4"	157	284
125	188	296	8.0	2.8	5"	186	297
150	212	308	8.8	3.3	6"	216	310
200	268	333	11.4	3.7	8"	270	334
250	320	358	13.0	4.5	10"	324	360
300	370	383	22.0	4.9	12"	381	385
350	430	423	29.3	-			
400	482	448	31.5	-			
500	585	498	39.0	-			
600	685	548	45.5	-			

All dimensions in mm

1) PVC / PP / PVDF versions deviate in part from the standard.



9.3.3. KFSE-EM

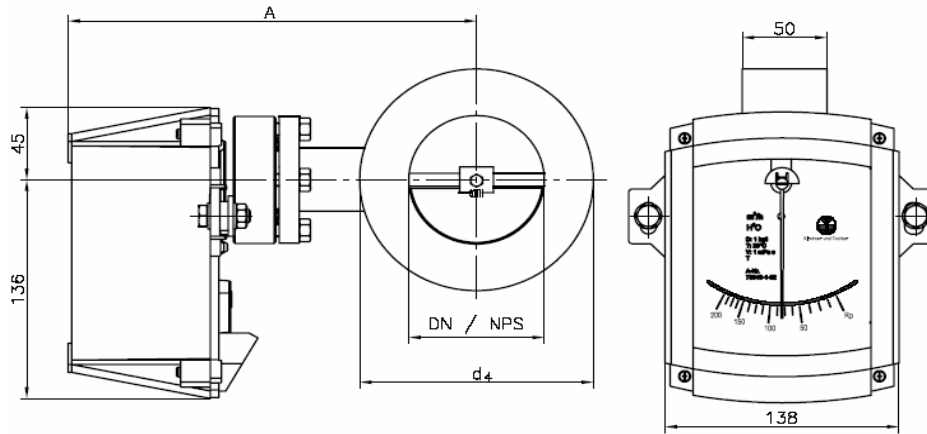

Note: The flap axis for DN32 and DN25 devices is located 9mm above the ring axis!
 NPS = Nominal pipe size acc. to ANSI / ASTM

DN	d4	A ¹⁾	Weight [kg]		NPS	d4	A ¹⁾
			Steel	PVC			
25	68	233	3.8	2.0	1"	51	233
32	78	236	3.8	2.0	1 1/4"	64	238
40	88	242	3.8	2.0	1 1/2"	73	240
50	102	247	3.9	2.1	2"	92	246
65	122	253	5.0	2.3	2 1/2"	105	251
80	138	260	5.6	2.5	3"	127	259
100	158	270	6.4	2.7	4"	157	271
125	188	283	8.0	2.8	5"	186	284
150	212	295	8.8	3.3	6"	216	297
200	268	320	11.4	3.7	8"	270	321
250	320	345	13.0	4.5	10"	324	347
300	370	370	22.0	4.9	12"	381	372
350	430	395	29.3	-			
400	482	420	31.5	-			
500	585	485	39.0	-			
600	685	535	45.5	-			

All dimensions in mm

¹⁾ PVC / PP / PVDF versions deviate in part from the standard.



9.4. Type examination certificate for KFS Ex and KFS-IK1 Ex



TÜV Rheinland Group

Baumusterprüfbescheinigung

(1) Geräte und Schutzsysteme zur bestimmungsgemäßen Verwendung in explosionsgefährdeten Bereichen - **Richtlinie 94/9/EG**

(2) Baumusterprüfbescheinigungsnummer

TÜV 03 ATEX 7041 X

(3) Gerät: **Klappendurchflussmessgerät KFS und KFS-IK-1**

(4) Hersteller: **A. Kirchner & Tochter GmbH**

(5) Anschrift: **D-47228 Duisburg
Dieselstraße 17**

(6) Die Bauart dieses Gerätes sowie die verschiedenen zulässigen Ausführungen sind in der Anlage zu dieser Baumusterprüfbescheinigung festgelegt.

(7) Die TÜV CERT-Zertifizierungsstelle für Ex-Schutz-Produkte der TÜV Industrie Service GmbH, TÜV Rheinland Group, bescheinigt die Erfüllung der grundlegenden Sicherheits- und Gesundheitsanforderungen für die Konzeption und den Bau von Geräten und Schutzsystemen zur bestimmungsgemäßen Verwendung in explosionsgefährdeten Bereichen gemäß Anhang II der Richtlinie 94/9/EG.

Die Ergebnisse der Prüfung sind in dem vertraulichen Prüfbericht Nr. 195/Ex041.00/03 festgelegt.

(8) Die grundlegenden Sicherheits- und Gesundheitsanforderungen werden erfüllt durch Übereinstimmung mit

EN 1127-1:1997 EN 13463-1:2001 EN 13463-5:2003

(9) Falls das Zeichen „X“ hinter der Bescheinigungsnummer steht, wird auf besondere Bedingungen für die sichere Anwendung des Gerätes in der Anlage zu dieser Bescheinigung hingewiesen.

(10) Diese Baumusterprüfbescheinigung bezieht sich nur auf Konzeption und Bau des festgelegten Gerätes gemäß Richtlinie 94/9/EG. Weitere Anforderungen dieser Richtlinie gelten für die Herstellung und das Inverkehrbringen dieses Gerätes. Diese Anforderungen werden durch diese Bescheinigung nicht abgedeckt

(11) Die Kennzeichnung des Gerätes muß die folgenden Angaben enthalten:

 **II 2G c IIC T4...T6**

TÜV Cert-Zertifizierungsstelle Köln, den 10.08.2004



Dipl.-Ing. K. Wettingfeld

Diese Baumusterprüfung darf nur unverändert weiterverbreitet werden.
Auszüge oder Änderungen bedürfen der Zustimmung der TÜV-Cert-Zertifizierungsstelle der TÜV Industrie Service GmbH,
TÜV Rheinland Group



9.5. Type examination certificate for KFSEM Ex



TÜV Rheinland Group

(1) **EG-Baumusterprüfbescheinigung**

(2) Geräte und Schutzsysteme zur bestimmungsgemäßen Verwendung in explosionsgefährdeten Bereichen - Richtlinie 94/9/EG

(3) EG-Baumusterprüfbescheinigungsnummer



TÜV 05 ATEX 7195

(4) **Gerät:** Klappendurchflussmessgerät KFS M9..... EEx

(5) **Hersteller:** Kirchner & Tochter GmbH

(6) **Anschrift:** 47228 Duisburg
Dieselstr.17

(7) Die Bauart dieses Gerätes sowie die verschiedenen zulässigen Ausführungen sind in der Anlage zu dieser Baumusterprüfbescheinigung festgelegt.

(8) Die TÜV CERT-Zertifizierungsstelle für Ex-Schutz-Produkte der TÜV Industrie Service GmbH, TÜV Rheinland Group, bescheinigt als benannte Stelle Nr. 0035 nach Artikel 9 der Richtlinie des Rates der Europäischen Gemeinschaften vom 23. März 1994 (94/9/EG) die Einhaltung der grundlegenden Sicherheits- und Gesundheitsanforderungen für die Konzeption und den Bau von Geräten und Schutzsystemen zur bestimmungsgemäßen Verwendung in explosionsgefährdeten Bereichen gemäß Anhang II der Richtlinie.
Die Ergebnisse der Prüfung sind in dem vertraulichen Prüfbericht Nr.: 194 /Ex 195.00 / 05 festgelegt.

(9) Die grundlegenden Sicherheits- und Gesundheitsanforderungen werden erfüllt durch Übereinstimmung mit
EN 60079-0: 2004 **EN 50020: 2002**

(10) Falls das Zeichen „X“ hinter der Bescheinigungsnummer steht, wird auf besondere Bedingungen für die sichere Anwendung des Gerätes in der Anlage zu dieser Bescheinigung hingewiesen.

(11) Diese EG-Baumusterprüfbescheinigung bezieht sich nur auf Konzeption und Prüfung des festgelegten Gerätes gemäß Richtlinie 94/9/EG. Weitere Anforderungen dieser Richtlinie gelten für die Herstellung und das Inverkehrbringen dieses Gerätes. Diese Anforderungen werden durch diese Bescheinigung nicht abgedeckt.

(12) Die Kennzeichnung des Gerätes muss die folgenden Angaben enthalten:

Ex II 2 G **Ex Ia IIC T6**



TÜV CERT-Zertifizierungsstelle für Explosionsschutz Köln, 11.08.05

Klaus Weitingfeld
Dipl.-Ing. Klaus Weitingfeld

Diese EG-Baumusterprüfbescheinigung hat ohne Unterschrift und Stempel keine Gültigkeit
Diese EG-Baumusterprüfbescheinigung darf nur unverändert verbreitet werden. Auszüge und Änderungen bedürfen der Genehmigung der
TÜV Cert Zertifizierungsstelle für Ex-Schutz-Produkte
TÜV Industrie Service GmbH TÜV Rheinland Group Am Grauen Stein 51105 Köln
Tel. +49 (0) 221 806-0 Fax. +49 (0) 221 806 114



9.6. 1. Addendum for KFS-EM Ex

		TÜV Rheinland Group
---	---	----------------------------

1. Ergänzung
gemäß Richtlinie 94/9/EG Anhang III Ziffer 6
zur EG-Baumusterprüfbescheinigung TÜV 05 ATEX 7195

Gerät:	Klappendurchflussmessgerät
Kennzeichnung:	KFS - EM EEx
Hersteller:	Kirchner & Tochter GmbH
Anschrift:	47228 Duisburg

Beschreibung der Ergänzungen und Änderungen:
Die ursprüngliche Typenbezeichnung KFS M9 ESKII EEx hat sich wie folgt geändert in:

KFS - EM EEx

Technische Daten

Keine Änderung

Prüfbericht-Nr. 194/Ex 195.01.05

TÜV CERT-Zertifizierungsstelle für Explosionsschutz	Köln, 21. Dezember 2005
---	-------------------------



Dipl.-Ing. Heinz Farke

Diese Ergänzung zur EG-Baumusterprüfbescheinigung hat ohne Unterschrift und Stempel keine Gültigkeit
Diese Ergänzung zur EG-Baumusterprüfbescheinigung darf nur unverändert verbreitet werden. Auszüge und Änderungen bedürfen der Genehmigung der TÜV Cert-Zertifizierungsstelle für Ex-Schutz-Produkte

TÜV Industrie Service GmbH TÜV Rheinland Group Am Grauen Stein 51105 Köln
Tel. +49 (0) 221 806-0 Fax. + 49 (0) 221 806 1396
Seite 1 / 1



9.7. 2. Addendum for KFS-EM Ex

		TÜV Rheinland Group
---	---	----------------------------

2. Ergänzung
gemäß Richtlinie 94/9/EG Anhang III Ziffer 6
zur EG-Baumusterprüfbescheinigung TÜV 05 ATEX 7195

Gerät: Klappendurchflussmessgerät

Kennzeichnung: KFS - EM EEx

Hersteller: Kirchner & Tochter GmbH

Anschrift: 47228 Duisburg

Beschreibung der Ergänzungen und Änderungen:

Der in den Klappendurchflussmessgerät KFS - EM EEx befindliche elektrische Signalausgang ESKII wird erweitert durch den elektrischen Signalausgang ESK 2A.

Technische Daten

Keine Änderung

Prüfbericht-Nr. 194/Ex 195.02.07

TÜV CERT-Zertifizierungsstelle für Explosionsschutz Köln, 12.03.07

Dipl.-Ing. Klaus Wettingfeld

Diese Ergänzung zur EG-Baumusterprüfbescheinigung hat ohne Unterschrift und Stempel keine Gültigkeit
Diese Ergänzung zur EG-Baumusterprüfbescheinigung darf nur unverändert verbreitet werden. Auszüge und Änderungen bedürfen der Genehmigung der TÜV Cert-Zertifizierungsstelle für Ex-Schutz-Produkte

TÜV Rheinland Industrie Service GmbH TÜV Rheinland Group Am Grauen Stein 51105 Köln
Tel. +49 (0) 221 806-0 Fax. + 49 (0) 221 806 1396
Seite 1 / 1



9.8. DIN EN ISO 9001:2008



CERTIFICATE

SQ-9001CM0074

for a quality management system according to ISO 9001

The company



Kirchner und Tochter

A. Kirchner & Tochter GmbH
 Dieselstraße 17, D-47228 Duisburg

has introduced a management system for

the development, production and marketing of flowmeters

and applies this management system. Compliance with the following standards was confirmed in a certification procedure:

DIN EN ISO 9001:2008 (December 2008)

Quality management systems; requirements

The application of the management system was demonstrated in a certification procedure based on the above requirements. The system is subject to annual surveillance.

This certificate expires on 1 March 2014

17.03.2011 Sz A

date, issued by, sheet, head of certification body

DVGW CERT GmbH ist von der DAkkS nach ISO/IEC 17021 akkreditiert für die Zertifizierung von Managementsystemen nach ISO 9001.

DVGW CERT GmbH is accredited by DAkkS according to ISO/IEC 17021 for certification of managementsystems according to ISO 9001.



Deutsche
 Akkreditierungsstelle
 D-ZM-16028-01-01

DVGW CERT GmbH
 Josef-Wirmer-Straße 1-3
 53123 Bonn

Telefon: +49 228 91 88-888
 Telefax: +49 228 91 88-993
 eMail: info@dvgw-cert.com



The equipment from Kirchner und Tochter has been tested in compliance with the applicable CE-regulations of the European Community. The respective declaration of conformity is available on request.

The Kirchner und Tochter QM-System is certified in accordance with DIN-EN-ISO 9001:2008.

Technical data supplied without liability. The current valid version of our documents can be found under this URL: www.kt-web.de

The quality is systematically adapted to the increasing demands.