



### Design and applications

Measuring units RA 60 and FA 60 are based on the variable area float principle. In pipelines the RA 60 is installed by means of screwed pipe joints and the FA 60 is mounted between flanges. The borosilicate glass measuring cone is located inside a protective steel tube with an inspection window.

VA flow meters RA 60 and FA 60 are most suitable for the flow measurement of transparent fluids and gases. Each unit is customized with a scale specific for the medium to be measured. RA 60 and FA 60 are used in plant engineering (e.g. furnace construction and water treatment).

By installation of electrical limit switches, which are adjustable throughout the entire measuring range, these units can be employed as detectors too.

Our technical documents provide a detailed explanation of the function and measuring principle of VA flow meters.



- calibrated borosilicate measuring cone
- armature with protective steel tube
- Perspex half-shell as shatter protection
- reliable due to simple mode of operation
- with limit switches usable as detectors
- scales specific for the media to be measured
- optionally explosion-protected design



**Kirchner und Tochter**



## RA 60/FA 60

### Types

Design	Description
RA 60	With threaded connection
FA 60	With flange connection

### Technical data

Nominal pressure	FA 60: PN 10 at 20 °C RA 60: PN 10 at 20 °C
Max. operating pressure	see table measuring ranges on page 3
Thermal endurance	80 °C, optionally 100 °C
Ambient temperature	90 °C
Turn-down ratio	1:10
Accuracy class	VDE/VDI 3513 page 2 (08/2008)
Error limit (G)	1,6 %
Liniar limit (qG)	50 %
Connection RA 60	Two-part pipe fitting: Insert with cylindrical internal thread to ISO 7-1
Connection FA 60	Flange PN 10 acc. to DIN EN 1092-1, other connections on request
Corrosion protection	Epoxy paint kiln-dried, traffic blue (RAL 5017), satin-finished
Corrosion class	C2

### Materials

Protective sleeve	Precision steel tube made of P235
Heads RA 60	Grey cast iron, (Aluminium from size 43)
Threaded joint	Malleable cast iron, galvanized
Flanges FA 60	S355
Measuring glass	Borosilicate glass
Splinter shield	Perspex
Gaskets	Standard: NBR, optionally FPM, EPDM
Floats for liquids <sup>1)</sup>	Standard: 1.4571, Special design: PVC, PP, PVDF or PTFE with lead core
Floats for gases <sup>1)</sup>	Standard: Aluminium anodized, optionally: PVC, PP, PTFE, PVDF or 1.4571
with limit contacts <sup>1)</sup>	Standard: 1.4571 with magnetic core or PVC with magnetic core

<sup>1)</sup> With small sizes VA flow meters floats unguided, from size 30 partly with guide rod. We will send you a detailed table on request.

### Dimensions

Size	Pipe fitting	RA 60			
		S	d <sup>1)</sup>	L	H
10	Rp ¼	28	12	388	28
	Rp ⅜	32	16	390	
	Rp ½	39	20	393	
19	Rp ½	39	20	405	45
	Rp ¾	48	25	407	
	Rp 1	55	32	415	
30	Rp 1	55	32	415	60
	Rp 1 ¼	67	40	430	
	Rp 1 ½	74	50	436	
36	Rp 1 ¼	67	40	430	75
	Rp 1 ½	74	50	436	
	Rp 2	90	63	446	
43	Rp 1 ½	74	50	440	95
	Rp 2	90	63	446	
	Rp 2 ½	111	75	460	
	Rp 3	131	90	470	
100	Rp 2	90	63	446	115
	Rp 2 ½	111	75	458	
	Rp 3	131	90	470	
110	Rp 2 ½	111	75	462	133
	Rp 3	131	90	474	

<sup>1)</sup> d for bonding and welding sleeves

Size	FA 60							
	DN	L	H	D	k	Screws		d <sub>2</sub>
						Qty	Thread	
10	10	340	28	90	60	4	M12	M12
	15			95	65	4	M12	M12
	20			105	75	4	M12	M12
	25			115	85	4	M12	M12
19	10	340	45	90	60	4	M12	M12
	15			95	65	4	M12	M12
	20			105	75	4	M12	M12
	25			115	85	4	M12	M12
30	25	340	60	115	85	4	M12	M12
	32			140	100	4	M16	M16
	40			150	110	4	M16	M16
36	32	340	75	140	100	4	M16	M16
	40			150	110	4	M16	M16
	50			165	125	4	M16	M16
43	40	340	95	150	110	4	M16	M16
	50			165	125	4	M16	M16
	65			185	145	4	M16	M16
100	65	340	115	185	145	4	M16	M16
	80			200	160	8	M16	M16
	100			220	180	8	M16	M16
110	65	340	133	185	145	4	M16	M16
	80			200	160	8	M16	M16
	100			220	180	8	M16	M16
	150			285	240	8	M20	M20
180	80 <sup>1)</sup>	640	178	220	160	8	M16	M16
	100			220	180	8	M16	M16
	125			250	210	8	M16	M16
	150			285	240	8	M20	M20
180	150	640	219	285	240	8	M20	M20
	200			340	295	8	M20	M20

<sup>1)</sup> Installation length: 655 mm

RA 60

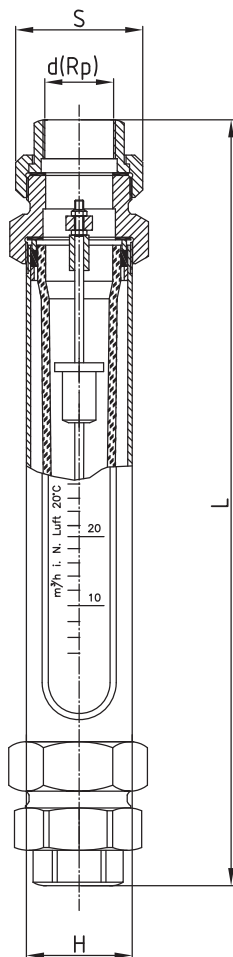

FA 60

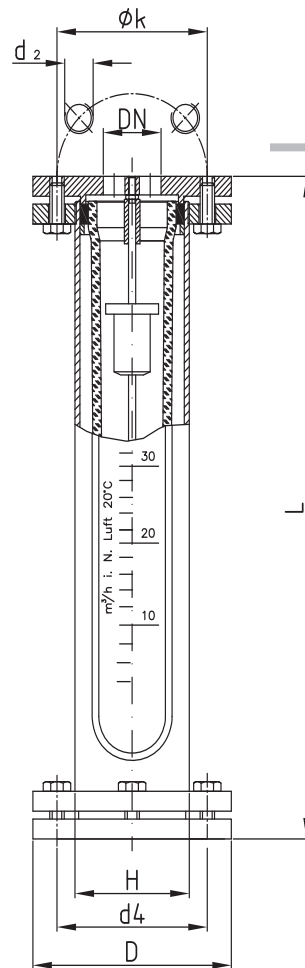

**Measuring range (min. and max. measuring range; all intermediate measuring ranges are possible)**

Size	Measuring range m³/h H2O		Measuring range m³/h air at STP <sup>1)</sup>		RA 60 Threaded connection	FA 60 Flange- connection DN	max. operating pressure bar		
10	0,1 15	- -	1 l/h 150 l/h	0,001 0,22	- -	0,01 2,2	Rp ¼ Rp ⅜ Rp ½	10 15 20 25	10
19	0,012 0,12	- -	0,12 1,2	0,15 1,6	- -	1,5 16	Rp ½ Rp ¾ Rp 1	10 15 20 25	10
30	0,1 0,3	- -	1 3	1,3 3,6	- -	13 36	Rp 1 Rp 1¼ Rp 1½	25 32 40	10
36	0,4 0,8	- -	4 8	4 8	- -	40 80	Rp 1¼ Rp 1½ Rp 2	32 40 50	8
43	0,9 1,6	- -	9 16	5 16	- -	50 160	Rp 1½ Rp 2 Rp 2½ Rp 3	40 50 65	8
100	1,6 2	- -	16 20	12 28	- -	120 280	Rp 2 Rp 2½ Rp 3	65 80 100	6
110	2,5 3	- -	25 30	14 44	- -	140 440	Rp 2½ Rp 3	65 80 100	5
150	5 10	- -	50 100	30 100	- -	300 1000	—	80 100 125 150	4
180	11 13	- -	110 130	30 150	- -	300 1500	—	150 200	3

Measuring ranges for other substances and operating conditions on request

<sup>1)</sup> at STP: at standard conditions (0 °C and 1,013 bar abs.)



### Limit switches MSK1/MSK12/MSKW

In order to realize a local display with a monitoring function the flowmeter can be equipped with limit switches. The limit switch consists of a connector housing and a bistable reed contact.

A magnet integrated in the float switches this reed contact. The limit switch is guided in a guide slot on the back of the protective tube and can be adjusted throughout the entire measuring range. In case of inductive or capacitive load applications, e.g. caused by contactors or solenoid valves, uncontrolled current and voltage peaks may occur. In dependence on their geometry such peaks also occur in lines, if they exceed a certain length. It is therefore recommended to use an additionally available arc suppression relay "MSR". This increases the switching capacity and avoids the appearance of inductive and capacitive peaks. It thereby ensures a long lifetime of the contact.

### Technical data of the limit switches

Design	MSK1	MSK12
Switching voltage	50V AC/75V DC	50V AC/75V DC
Switched current	0,5 A	0,5 A
Switching capacity	10 W/VA	10 W/VA
Dielectric strength	230V AC/400V DC	230V AC/400V DC
Temperature range <sup>1)</sup>	-20 to +90°C	-20 to +90°C
Switching function	Normally closed	Normally open
Connection		

Design	MSKW
Switching voltage	50V AC/75V DC
Switched current	0,5 A
Switching capacity	5 W/VA
Dielectric strength	110V AC/200V DC
Temperature range <sup>1)</sup>	-20 to +90°C
Switching function	change over
Connection	

<sup>1)</sup> the deciding factor is the thermal endurance of the flow meter

### Low voltage directive

Above 50 V AC/ 75 V DC, contacts are subject to the EU Low-Voltage Directive. The user is required to verify their use accordingly.

### Proper use

The user is responsible for assessing the suitability of the flow meters for his case of application, for use as prescribed, and for material compatibility as regards the liquid product used in his process.

The manufacturer shall not be liable for any damage arising from incorrect or improper use of the devices.

Pressure surges can cause glass breakage, and should therefore generally be avoided. The limit values given in the data sheet should be observed.

In all other respects we advise following the installation recommendations specified in Code VDI/VDE 3513, Sheet 3.

The equipment from **Kirchner und Tochter** has been tested in compliance with applicable CE-regulations of the European Community.

The respective declaration of conformity is available on request.

Technical data supplied without liability. The current valid version of our documents can be found under this URL: [www.kt-web.de](http://www.kt-web.de)

The **Kirchner und Tochter** QM-System is certified in accordance with DIN-EN-ISO 9001:2008. The quality is systematically adapted to the continuously increasing demands.



**Kirchner und Tochter**

A. Kirchner & Tochter GmbH

Dieselstraße 17 · D-47228 Duisburg

Fon: +49 2065 9609-0 · Fax: +49 2065 9609-22

[www.kirchnerundtochter.de](http://www.kirchnerundtochter.de) · [info@kirchnerundtochter.de](mailto:info@kirchnerundtochter.de)