

VA-flow meter



RA 87 / FA 87



Assembly and operating Instructions
Variable Area Flow Meters
RA 87 / FA 87



Kirchner und Tochter

A. Kirchner & Tochter GmbH Dieselstraße 17 · D-47228 Duisburg
Fon: +49 2065 9609-0 · Fax: +49 2065 9609-22 Internet: www.kt-web.de · e-mail: info@kt-web.de
Version 2.6



Contents

| | | |
|-------|--|----|
| 1. | Foreword..... | 3 |
| 2. | Safety..... | 3 |
| 2.1. | Symbol and meaning..... | 3 |
| 2.2. | General safety directions and exemption from liability..... | 3 |
| 2.3. | Intended use..... | 3 |
| 2.4. | Special safety instructions concerning glass devices..... | 4 |
| 2.5. | Safety information for Operator and operating personnel..... | 4 |
| 2.6. | Regulations and guidelines..... | 4 |
| 2.7. | Notice as required by the hazardous materials directive..... | 4 |
| 3. | Transport and storage..... | 4 |
| 4. | Installation..... | 5 |
| 4.1. | Work preparatory to installation..... | 5 |
| 4.2. | Preparation of the measuring device:..... | 5 |
| 4.3. | Installation RA 87 G..... | 7 |
| 4.4. | Installation RA 87 Rp..... | 7 |
| 4.5. | Installation FA 87 DN..... | 7 |
| 5. | Start-up..... | 7 |
| 6. | Readings in operation..... | 7 |
| 7. | Limit switches MSK1 / MSK12 / MSKW..... | 8 |
| 7.1. | Connection of limit switches..... | 8 |
| 7.2. | Setting the limit switches..... | 8 |
| 8. | Linear displacement sensor 4-20mA / 1-10V..... | 9 |
| 8.1. | Connection of the linear displacement sensor..... | 9 |
| 8.2. | Setting the sensor..... | 10 |
| 8.3. | Technical data..... | 10 |
| 9. | Maintenance and cleaning of the flow meter..... | 11 |
| 9.1. | Dismantling of the measuring glass..... | 11 |
| 9.2. | Installation of the measuring glass..... | 11 |
| 9.3. | Replacement of measuring glass..... | 12 |
| 10. | Service..... | 12 |
| 10.1. | Disposal..... | 12 |
| 11. | Technical data..... | 13 |
| 11.1. | Materials..... | 14 |
| 11.2. | Measuring ranges..... | 15 |
| 11.3. | Dimensions..... | 16 |
| 11.4. | Technical data of limit switches..... | 19 |
| 11.5. | Low-voltage directive..... | 19 |



1. Foreword

These Installation and Operating Instructions are applicable to devices of Series RA 87 and FA 87. Please follow all instructions and information given for installation, operation, inspection and maintenance. The Instructions form a component part of the device, and should be kept in an appropriate place accessible to the personnel in the vicinity of the location. Where various plant components are operated together, the operating instructions pertaining to the other devices should also be observed.

2. Safety

2.1. Symbol and meaning



Safety notice

This symbol is placed against all directions/information relating to occupational health and safety in these Installation and Operating Instructions, and draws attention to danger to life and limb. Such notices should be strictly observed.

2.2. General safety directions and exemption from liability

This document contains basic instructions for the installation, operation, inspection and maintenance of the variable area flow meter. Non-observance of these directions can lead to hazardous situations for man and beast and also to damage to property, for which Kirchner und Tochter disclaims all liability.

The operator is required to rule out potentially hazardous situations through voltage and released media energy.

2.3. Intended use

The Series RA 87 / FA 87 device is a variable area flow meter designed for liquids and gases, and for installation in vertical pipe runs. Installation in the pipeline should be carried out solely in accordance with these Instructions. The required version of variable area flow meter should be selected on the basis of the pipe diameter at the point of use of the device. The limit values pertaining to the device are given in Section 10 and should not be exceeded. Modifications or other alterations to the flow meter may only be carried out by Kirchner und Tochter. Installation in horizontal pipe runs is possible using appropriate pipe bends. The direction of flow must always be from bottom to top. Details of the process product and the operating conditions are marked on the measuring glass.



2.4. Special safety instructions concerning glass devices



For safety reasons, we recommend fitting a protective shield in front of the measuring tube when starting up flow meters fitted with glass measuring tubes. The devices should not be operated where there is a risk of pressure surges (water hammer)!

To avoid glass breakage, all fitting work between measuring glass and heads inside the glass should be carried out by twisting and simultaneously pressing after having wetted the packing rings/gaskets.

2.5. Safety information for Operator and operating personnel

Authorized installation, operating, inspection and maintenance personnel should be suitably qualified for the jobs assigned to them, and should receive appropriate training and instruction.

2.6. Regulations and guidelines

In addition to the directions given in these Installation and Operating Instructions, observe the regulations, guidelines and standards, such as DIN EN, and, for specific applications, the codes of practice issued by DVGW (gas and water) and VdS (underwriters), or the equivalent national codes, and applicable national accident prevention regulations.

2.7. Notice as required by the hazardous materials directive

In accordance with the law concerning handling of waste (critical waste) and the hazardous materials directive (general duty to protect), we would point out that all flow meters returned to Kirchner und Tochter for repair are required to be free from any and all hazardous substances (alkaline solutions, acids, solvents, etc.).



Make sure that devices are thoroughly rinsed out to neutralize hazardous substances.

3. Transport and storage

Always use the original packing for transport, handling and storage. Protect the device against rough handling, impact, jolts, etc.



4. Installation

4.1. Work preparatory to installation

Preparation of the installation point:

Check the pipe run at the point of installation. Variable area flow meters are only suitable for vertical installation and an upward flow direction (from bottom to top). For all other installation situations, appropriate pipe bends need to be fitted in the existing pipeline to ensure upward vertical flow through the device.

The region of steady flow should be 4 to 6 x DN upstream and downstream of the location. Control equipment for gaseous media in particular should be installed downstream of the flow meter.

If necessary, support the pipeline on both sides of the flow meter to prevent vibration from being transferred to the device.

Before connecting, clean the pipelines leading to the device by blowing out or flushing.

For Type RA 87 Rp with external pipe thread, additionally fit both free ends of the pipe with the pipe unions on the flow meter before installation.

The measuring device is inserted either by using appropriate gaskets with the union nuts at the ends of the pipe (RA 87 Rp) or direct on the ends of the pipe or screw-in connection with a suitable open-end spanner at the device head (RA 87 G). The FA 87 meter is sealed off from the pipeline by flat gaskets, and the RA 87 G meter using appropriate packing material or screw-in connections. After it has been installed, the measuring device should not be turned any more.

Pay attention to the correct spacing of the sealing faces and to exact alignment.

Under no circumstances should the variable area flow meter be used to draw the pipe ends together (install free of stresses!). Do not over-tighten the union nuts.

4.2. Preparation of the measuring device:

1. Remove the device from the transport packing.
2. Remove the transport protection stoppers from the ends of the device.
3. Pull the float securing rod out of the device (PVC red or grey).
4. Check that the float can move freely in the device.
5. Have ready: flat gaskets (FA 87) or packing material such as hemp (RA 87). These are not included with the supply.

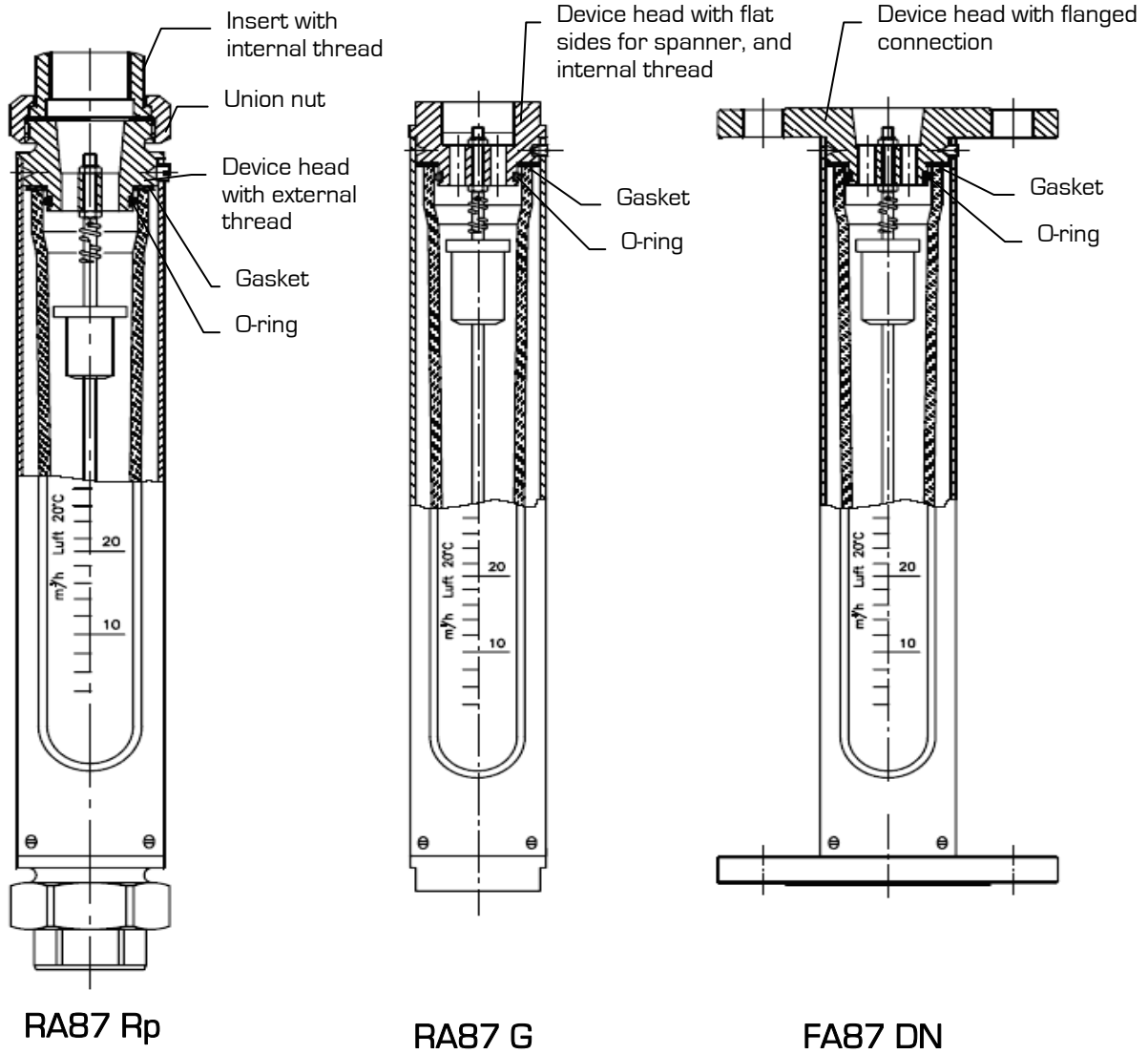



4.3. Installation RA 87 G

When screwing in adjacent fittings, use the flat sides at the ends of the device for counter-holding with a suitable open-end spanner. Use suitable packing material.

4.4. Installation RA 87 Rp

1. Dismantle the inserts and the union nuts from the device.
2. Slide the union nuts over the ends of the pipeline at the installation point.
3. Screw the inserts using packing material on to the pipe ends.
4. Slide the device with the gaskets at both ends into the installation point.
5. Screw the union nuts back on the device heads and tighten down such that the device is seated in the pipeline without stresses.

4.5. Installation FA 87 DN

1. Slide the device with the flat gaskets (not included with supply) at both ends into the installation point.
2. Check that the gaskets are in alignment and make sure they do not project into the pipeline.
3. Attach bolts and nuts loosely to the flanged connection.
4. Tighten bolts on the flanged connection in diagonally opposite sequence so that the device is fastened in the pipeline without stresses.

5. Start-up

The device must be properly installed before it is started up.

1. Check all device connections.
2. To set the flow: pressurize the pipelines by slowly opening the shut-off valves (risk of glass breakage!). On liquid service: carefully evacuate the pipeline.
3. Check the leak-tightness of all components and, if necessary, tighten down threaded joints or screw connections.

6. Readings in operation

The flow value is read off from the scale on the glass cone at the top edge of the float. The measured-value readings are only correct when the operating condition at the measuring point (flowing medium, operating pressure and temperature) corresponds to the values marked on the measuring glass. If operating conditions should differ, the measured value must be corrected with the aid of the general float equation, which you will find in our technical documents.

You can also do the recalculation with the help of our conversion program given on our homepage: www.kt-web.de, Section "Physical Basics".



7. Limit switches MSK1 / MSK12 / MSKW

The flow meter can be equipped with limit switches to provide local indication with monitoring function.

The limit switches consist of a limit switch (reed switch) that is switched over by the magnet integrated in the float .

The limit switch is guided in a guide slot in the protective case and can be adjusted over the full measuring range. The reed switches have a bistable characteristic.

Uncontrolled current and voltage peaks can occur in the case of inductive or capacitive loads, e.g. from contactors or solenoid valves. Such peaks will also occur, depending on cable geometry, where cables exceed a certain length.

We therefore recommend using an MSR contact protection relay, which is additionally available. This will increase the contact rating and prevent occurrence of inductive and capacitive peaks, thus ensuring long service life of the contacts.

Electrical data and limit values are specified in Section 10.

7.1. Connection of limit switches



Electrical connection of the device must be carried out in conformity with the relevant VDE regulations (or equivalent national standards) and in accordance with the regulations issued by the local power supply utility.

1. Disconnect the plant from supply before connecting the limit switch.
2. Provide a protective circuit for the switches in keeping with their capacity.
3. Connect line-side fuse elements matched to consumption.
4. Connect the cable using the supplied right-angle plug. Assigned are terminals 1 and 2. Earth and terminal 3 are not assigned. The circuit diagram for limit switches is shown in the Technical Data , Section 10.2 on page 19.

7.2. Setting the limit switches

1. Loosen the lock nut M8 on the neck of the switch.
2. Slide the switch to the flow value required to be monitored.
3. Please make sure the contact never touches the measuring glass and the clearance between contact and glass is always approx. 1 mm. This clearance can be obtained by turning the contact in the sliding block.
4. Test the switching characteristic by moving the float over and beyond the switching position.
5. Retighten the lock nut. **Maximum fastening torque is 2 Nm.**



8. Linear displacement sensor 4-20mA / 1-10V

Operating principle:

The linear displacement sensor based on the Hall principle delivers an output signal proportional to the height setting of the flow meter.
The can be displayed in 4-20mA or 0-10V.

The sensor is connected via the enclosed M12 x 1mm connector.

Please notice that the sensor has a blind zone in the range of 3.7mA to around 4 mA and performs stable operation only after approx. 4mA.

8.1. Connection of the linear displacement sensor



The electrical connection of the device must be performed according to the pertinent VDE regulations, as well as the regulations of the local power company.

1. Disconnect electric power from the system before connecting the sensor.
2. Provide a protective circuit of the sensor corresponding to its output.
3. Connect the protective elements suitable for use upstream.
4. The cable connection is done on the enclosed angle connector. The circuit diagram for the sensor is in the following illustration:

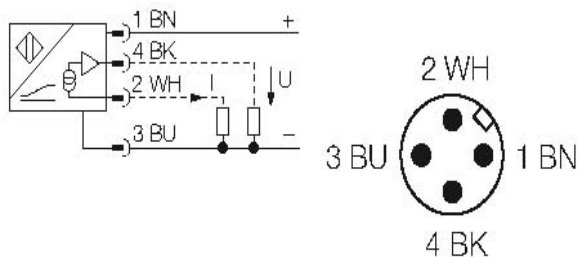



8.2. Setting the sensor

Normally the linear displacement sensor is delivered set on the lowest measurement range point. This corresponds in this condition to 4mA.

The other measurement range or mA values can be found in the enclosed protocol.

If you want to set the 4 mA value to another measurement range point, slide the sensor or the 4mA value to the desired point.

To do this again loosen the two outer nuts with their toothed washers. Next loosen the two setscrews by approx. one revolution. Now you can put the sensor in the desired position, and retighten the setscrews and the nuts.

Next move to each following scale mark to determine the mA value belonging to it.

8.3. Technical data

| | |
|---|--|
| Measurement range [A..B] | 160 mm |
| Repeatability | < 0.1 % from measurement range IA-BI < dependent upon position sensor |
| Linearity deviation | <1 % v. E. |
| Temperature drift | <±0.006%/K |
| Ambient temperature | -25...+ 70 °C |
| Operating voltage | 15 – 30 VDC |
| Residual ripple | < 10 % U _{ss} |
| Idle current I ₀ | < 15 mA |
| Rated insulation voltage | < 0.5 kV |
| Short circuit protection | yes |
| Fail-safe circuit / reverse polarity protection | yes/ complete |
| Output function | four-wire, analogue output |
| Voltage output | 0... 10V |
| Current output | 4 – 20 mA |
| Load resistor voltage output | >4.7 k |
| Load resistor current output | <0.4 k |
| Recovery time at output | < 15 ms |
| Sampling rate | 200 Hz |
| Type | Quader, Q25L |
| Dimensions | 201 x 35 x 25 mm |
| Housing material | Aluminium |
| Material of active surface | Plastic, PC-GF20 |
| Connection | Plug connector, M12x1 |
| Vibration resistance | 55 Hz{1 mm} |
| Shock resistance | 30g {11 ms} |
| Protection class | IP67 |
| Operating voltage display | LED green |
| Measurement range display | LED, yellow, position sensor in detection range |



9. Maintenance and cleaning of the flow meter

The device is maintenance-free. Should the glass cone become fouled, the device can be dismantled after being removed from the pipeline.

9.1. Dismantling of the measuring glass

To remove the measuring glass out of the device, perform the activities, which are described in chapter 3.3, no 1 and no. 2. Now the parts can be cleaned.

9.2. Installation of the measuring glass



To avoid damages and wrong readings, you have to pay special attention to the correct installation of the appropriate gaskets and the float/float stop.

To install the device perform the activities, which are described in chapter 9.3, no. 3 to no. 12.



9.3. Replacement of measuring glass

Refer to the Figure on page 6.

1. Remove the device from the installation point. Detach the lateral retaining screws and remove the heads from the glass by simultaneously twisting and pulling them out of the glass. On devices with guide rod, leave the rod mounted on the upper head!
2. On devices with non-guided floats, remove the float stops and the float from the old glass.
3. Insert the float stops and the float into the new glass. Screw the float stops (helical springs made of VA steel) carefully with a pair of pliers into the glass ends (risk of glass breakage!).
4. Fit the device heads with new O-rings and gaskets.
5. Wet the O-ring before assembling glass and head.
6. Carefully slide the lower device head into the bottom opening of the measuring glass, twisting and pushing simultaneously (risk of glass breakage!).
7. Insert the glass with head into the case, making sure not to knock the glass against the case.
8. Fasten the device head with the retaining screws to the case.
9. Align the glass cone so that the inscriptions can be read off through the viewing window in the case.
10. Slide the second head with wetted O-ring by simultaneously twisting and pushing it into the upper opening of the measuring glass, or steel case. Also lock the head in place on the case.
11. On devices with guide rod, check float mobility. If necessary, correct the position by turning the guide rod (to do this, hold the plain end of the guide rod at the lower head with a pair of engineer's pliers, or similar tool, and slightly loosen the M5 screw on the opposite side).
12. Reinstall the device in the installation point.

10. Service

All devices with defects or deficiencies should be sent direct to our repair department. To enable our customer service facility to deal with complaints and repairs as quickly as possible, you are kindly requested to coordinate the return of devices with our sales department, Tel. +49 2065-96090.

10.1. Disposal

Please help to protect our environment, and dispose of workpieces in conformity with current regulations or use them for some other purpose.



11. Technical data

| | | |
|-------------------------|---|---------------------------|
| Nom. pressure rating | FA 87: PN 10 at 20°C RA 87: PN 10 at 20°C | |
| Max. operating pressure | Size acc. table 10.3, 9,5; 19; 30 36; 43 | pressure [bar] 10 8 |
| Thermal endurance | 80°C; optionally: 100°C | |
| Ambient temperature | 90°C | |
| Turndown ratio | 01:10 | |
| Accuracy class | 1.6 to VDI/VDE 3513 | |
| Connection RA 87 | 1) cylindrical internal fastening thread to ISO 288 2) two-part pipe union Insert with cylindrical internal thread to ISO 7-1 | |
| Connection FA 87 | Flanges PN 10 to DIN 2501, others (ANSI, JIS, ...) on request | |



11.1. Materials

| | |
|-------------------------------------|---|
| Protective case | 1.4301 stainless steel |
| Heads RA 87 | 1.4571 stainless steel |
| 2-part threaded joint | 1.4404 / 1.4571 stainless steel |
| Flanges FA 87 | 1.4571 stainless steel |
| Measuring glass | Borosilicate glass |
| Shatterproof glass | Perspex |
| O-ring seals | Standard: Viton, optionally EPDM, FFKM, silicone, Perlast |
| Gaskets | not wetted: NBR, otherwise Viton (RA 87 Rp) |
| Float for liquids 1) | Standard: 1.4571; optionally: Hastelloy C4 |
| Floats for gases 1) | Standard: PTFE; optionally: PVC, PVDF, PP, aluminium |
| with limit contacts 1) | Standard: 1.4571 (stainless steel) with magnetic core For air: PVC with magnetic core, optionally: PP, PVDF or PTFE (each with magnetic core) |
| Special version: RA 87 and FA 87 | Corrosion protection for all wetted parts PVC, PP, PVDF, PTFE |

1) Floats up to size 19 are non-guided, floats from size 30 on are guided. Optional sizes 9,5 (without magnetic core for limit switches) and 19 also available as guided floats.



11.2. Measuring ranges

| Size | Measuring range: m ³ /h | | | Measuring range m ³ /h air at STP ¹⁾ | | | | | |
|------|------------------------------------|---|--------|--|---|--------|---------|---|--------|
| | H ₂ O float | | | float | | | float | | |
| | All materials | | | Teflon [®] , PVDF | | | PVC, PP | | |
| 9,5 | 0,5l/h | - | 5l/h | 0,008 | - | 0,08 | 0,008 | - | 0,08 |
| | 20l/h | - | 200l/h | 0,280 | - | 2,80 | 0,200 | - | 2,00 |
| 19 | 0,012 | - | 0,12 | 0,150 | - | 1,50 | 0,140 | - | 1,40 |
| | 0,120 | - | 1,20 | 1,600 | - | 16,00 | 1,200 | - | 12,00 |
| 30 | 0,100 | - | 1,00 | 1,200 | - | 12,00 | 0,850 | - | 8,50 |
| | 0,300 | - | 3,00 | 3,000 | - | 30,00 | 2,000 | - | 30,00 |
| 36 | 0,400 | - | 4,00 | 3,500 | - | 35,00 | 2,500 | - | 25,00 |
| | 0,800 | - | 8,00 | 8,000 | - | 80,00 | 5,000 | - | 50,00 |
| 43 | 0,900 | - | 9,00 | 8,000 | - | 80,00 | 6,000 | - | 60,00 |
| | 1,600 | - | 16,00 | 16,000 | - | 160,00 | 12,000 | - | 120,00 |

¹⁾ at STP: at standard conditions (0 °C and 1.013 bar abs.)



11.3. Dimensions

| RA 87 with internal thread | | | | | | |
|----------------------------|-------|----|-----------------|-----------------|-----|------|
| Size | G | DN | S ²⁾ | d ¹⁾ | L | H |
| 9,5 | 1/4 | 10 | 20 | 12 | 266 | 25 |
| | 3/8 | 15 | | 16 | | |
| 19 | 1/2 | 15 | 40 | 20 | 366 | 44,5 |
| | 3/4 | 20 | | 25 | | |
| 30 | 1 | 25 | 55 | 32 | 366 | 60 |
| | 1 1/4 | 32 | | 40 | | |
| 36 | 1 1/4 | 32 | 65 | 40 | 366 | 70 |
| | 1 1/2 | 40 | | 50 | | |
| 43 | 1 1/2 | 40 | 82 | 50 | 366 | 89 |
| | 2 | 50 | | 63 | | |

1) only with plastics PVC cemented sleeves and PP, PVDF welding sleeves

2) only for 1.4571 version (stainless steel)

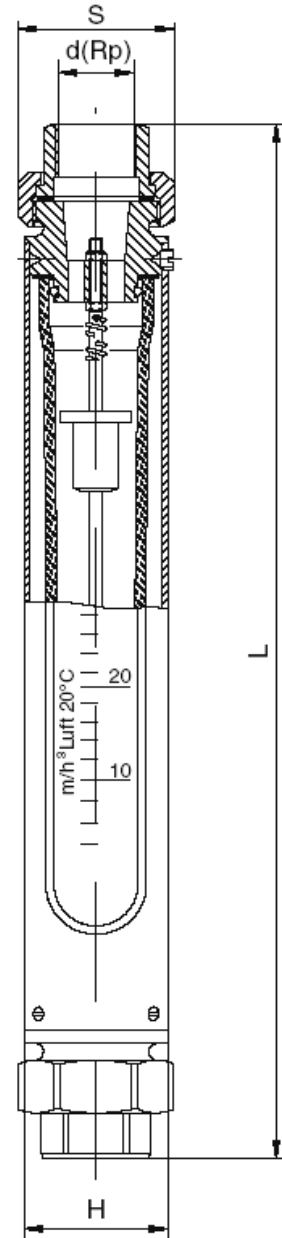



RA 87 / FA 87

| RA 87 with screwed pipe connection | | | | | | | | |
|------------------------------------|----------------|-----|----|------------------|-----------------|---------|--------------|------|
| Size | 1.4571 Version | | | plastics version | | | | |
| | Thread | L | S | DN | d ¹⁾ | L (PVC) | L (PP, PVDF) | H |
| 9,5 | Rp 1/4 | 306 | 27 | 10 | 16 | 302 | 304 | 25 |
| | Rp 3/8 | 309 | 32 | 15 | 20 | 305 | 305 | |
| | Rp 1/2 | 314 | 41 | | | | | |
| 19 | Rp 1/2 | 414 | 41 | 15 | 20 | 405 | 405 | 44,5 |
| | Rp 3/4 | 416 | 50 | 20 | 25 | 411 | 409 | |
| | Rp 1 | 422 | 55 | 25 | 32 | 417 | 413 | |
| 30 | Rp 1 | 422 | 55 | 25 | 32 | 423 | 419 | 60 |
| | Rp 1 1/4 | 428 | 70 | 32 | 40 | 432 | 424 | |
| | Rp 1 1/2 | 429 | 75 | 40 | 50 | 442 | 430 | |
| 36 | Rp 1 1/4 | 428 | 70 | 32 | 40 | 432 | 424 | 70 |
| | Rp 1 1/2 | 429 | 75 | 40 | 50 | 442 | 430 | |
| | Rp 2 | 433 | 90 | 50 | 63 | 456 | 438 | |
| 43 | Rp 1 1/2 | 429 | 75 | 40 | 50 | 448 | 436 | 89 |
| | Rp 2 | 433 | 90 | 50 | 63 | 462 | 444 | |

¹⁾ only with plastics PVC cemented sleeves
and PP, PVDF welding sleeves

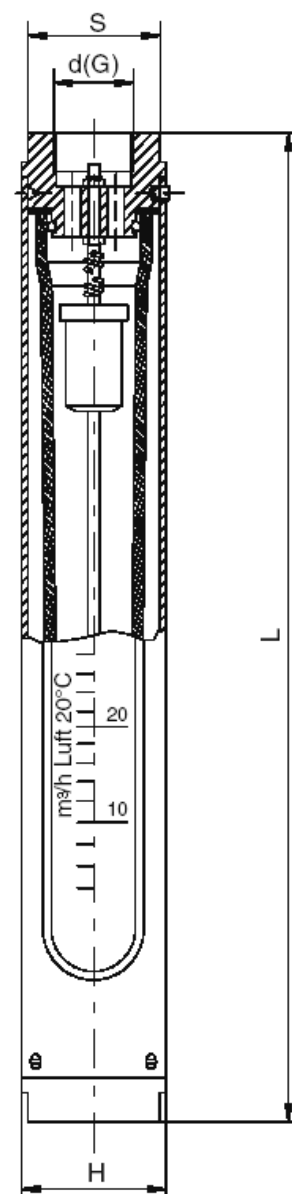



| FA 87 | | | | | | | | | |
|-------|----|-----|------|-----|-----|-----|----------|--------|-----|
| Size | DN | L | H | D | d4 | k | Screws | | |
| | | | | | | | Quantity | Thread | d2 |
| 9,5 | 10 | 260 | 25 | 90 | 40 | 60 | 4 | M 12 | 14 |
| | 15 | | | 95 | 45 | 65 | 4 | M 12 | 14 |
| 19 | 10 | 360 | 44,5 | 90 | 40 | 60 | 4 | M 12 | M12 |
| | 15 | | | 95 | 45 | 65 | 4 | M 12 | 14 |
| | 20 | | | 105 | 58 | 75 | 4 | M 12 | 14 |
| 30 | 25 | 360 | 60 | 115 | 68 | 85 | 4 | M 12 | 14 |
| | 40 | | | 150 | 88 | 110 | 4 | M 16 | 18 |
| 36 | 40 | 360 | 70 | 150 | 88 | 110 | 4 | M 16 | 18 |
| | 50 | | | 165 | 102 | 125 | 4 | M 16 | 18 |
| 43 | 50 | 360 | 89 | 165 | 102 | 125 | 4 | M 16 | 18 |
| | 65 | | | 185 | 122 | 145 | 4 | M 16 | 18 |

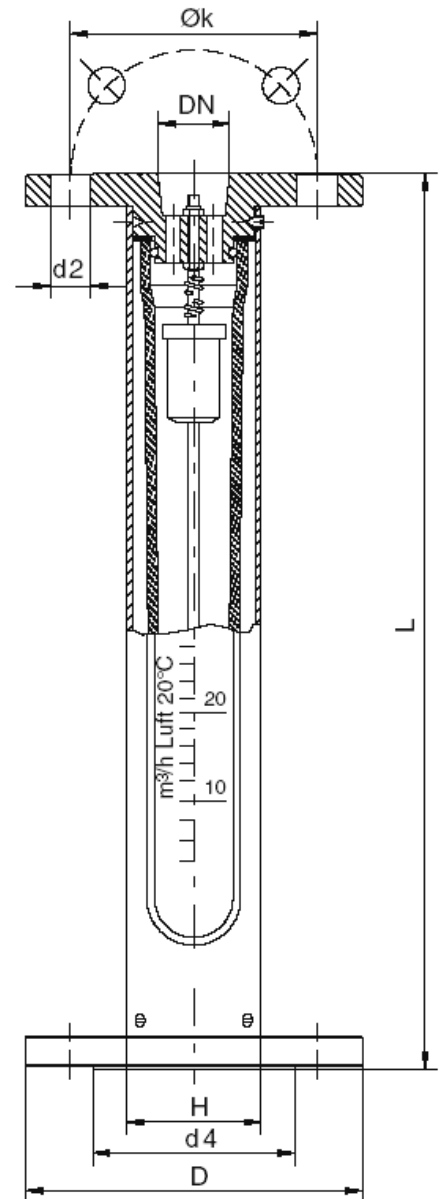



11.4. Technical data of limit switches

| Design | MSK1 | MSK12 |
|---------------------|-------------------------|-----------------------|
| Voltage switched | 50VAC/75VDC | 50VAC/75VDC |
| Current switched | 0,5A | 0,5A |
| Contact rating | 10W/VA | 10W/VA |
| Dielectric strength | 230VAC/400VDC | 230VAC/400VDC |
| Temperature range | -20 bis +90°C | -20 bis +90°C |
| Switching function | normally closed contact | normally open contact |
| Connection | | |
| Design | MSKW | |
| Voltage switched | 50VAC/75VDC | |
| Current switched | 0,5A | |
| Contact rating | 5W/VA | |
| Dielectric strength | 110VAC/200VDC | |
| Temperature range | -20 bis +90°C | |
| Switching function | change over contact | |
| Connection | | |

¹⁾ The deciding factor is the thermal endurance of the flow meter!
 Connection via right angle plug M12x1

11.5. Low-voltage directive

Above 50 V AC/75 V DC, contacts are subject to the EU Low-Voltage Directive.
 The user is required to verify their use accordingly.



The equipment from Kirchner und Tochter has been tested in compliance with applicable CE-regulations of the European Community.

The respective declaration of conformity is available on request.

The Kirchner und Tochter QM-System is certified in accordance with DIN-EN-ISO 9001:2008. The quality is systematically adapted to the continuously increasing demands.