



### Design and application

In all cases where a dependable device is required for indicating instantaneous values and monitoring the flow in pipelines, the SGM is the obvious choice as a reliable device for measuring the flow of liquids and gases. Since the vertical position of the float is transmitted magnetically to a dial gauge, the SGM, as opposed to standard type variable area flow meters with a glass tube, is also suitable for measuring the flow of opaque media. Each device is individually calibrated to meet customer specifics and fitted with a medium specific scale.

For process control, the flow meter can be equipped with a limit switch and/or measuring transmitter with electrical analog output.

The function of the SGM is based on the float principle. Our technical documents provide a detailed explanation of the function and measuring principle of VA flow meters.



- All-metal device, indication via magnetic coupling
- High resistance to pressure and temperature
- DN 15 to DN 100
- Low pressure loss
- Limit switch
- Analog output 4-20 mA
- Optionally available in explosion-protected design
- On request with PTFE liner
- **CE** 0085BN0048
- Optionally available for horizontal installation



**Kirchner und Tochter**

A. Kirchner & Tochter GmbH Dieselstraße 17 · D-47228 Duisburg  
Fon: +49 2065 9609-0 · Fax: +49 2065 9609-22 Internet: www.kt-web.de · e-mail: info@kt-web.de



## SGM

### Series

Version	Description
SGM	All-metal device
SGM-EM	with electrical signal output
SGM-EMZ	with electrical signal output and totalizer
SGM-IK1	with one inductive switch (SC3,5-N0-Y)
SGM-IK2	with two inductive switches (SC3,5-N0-Y)
SGM-IKS1	with one electronic switch (SB3,5-E2)
SGM-IKS2	with two electronic switches (SB3,5-E2)
SGM-IK1-EM	with one inductive switch and with electrical signal output
SGM-IK1-EMZ	with one inductive switch and with electrical signal output and totalizer
SGM-IK2-EM	with two inductive switches and with electrical signal output
SGM-IK2-EMZ	with two inductive switches and with electrical signal output and totalizer
SGM-IKS1-EM	with one electronic switch and with electrical signal output
SGM-IKS1-EMZ	with one electronic switch and with electrical signal output and totalizer
SGM-IKS2-EM	with two electronic switches and with electrical signal output
SGM-IKS2-EMZ	with two electronic switches and with electrical signal output and totalizer
Optionally	Version/Description
SGM EEx	All-metal device, explosion-protected design
SGM-EM EEx	with electrical signal output, explosion-protected design
SGM-IK1 EEx	with one inductive switch, explosion-protected design
SGM-IK2 EEx	with two inductive switches, explosion-protected design
SGM-IK1-EM EEx	with one inductive switch and with electrical signal output, explosion-protected design
SGM-IK2-EM EEx	with two inductive switches and with electrical signal output, explosion-protected design

### Technical data

Accuracy class	
Standard (VA/C <sub>4</sub> )	1,6 to VDE/VDI 3513
alt. (PTFE/ceramics)	2,5 to VDE/VDI 3513
Indicator part	
Scale	in phy. units, e.g. l/h, m <sup>3</sup> /h
Scale length	90 mm
Turndown ratio	1:10
Degree of protection, indicator part	IP 67, NEMA 4X
Stainless steel version	
Allowable operating pressure	
DN 15, DN 25, DN 50	PN 40
DN 80, DN 100	PN 16
PTFE version	
Allowable working pressure	same as for stainless steel version
Connections	
	Flanges to DIN 2501 (EN-1092-1), on request: ANSI B 16.5, JIS, DIN 11851, screw connection to ISO 228

### Materials

Version	Measuring tube/float	Temperature	Env.-
SGM / VA	st. steel/st. steel	- 80°C ... + 300°C	≤ 120°C
SGM / C <sub>4</sub>	Hastelloy C <sub>4</sub> /Hastelloy C <sub>4</sub>	- 80°C ... + 300°C	≤ 120°C
SGM / PTFE	PTFE <sup>1)</sup> /PTFE	70°C	≤ 70°C
SGM / PTFE / K	PTFE <sup>1)</sup> /ceramic	150°C	≤ 70°C
SGM / TFM / K	TFM <sup>1)</sup> /ceramic	250°C	≤ 120°C
Indicator part:			
Scale case	aluminium, painted		
Pointer	aluminium, painted		
Scale	aluminium, coated		
Pane	float glass		

<sup>1)</sup> Measuring tube of stainless steel (1.4404) with liner

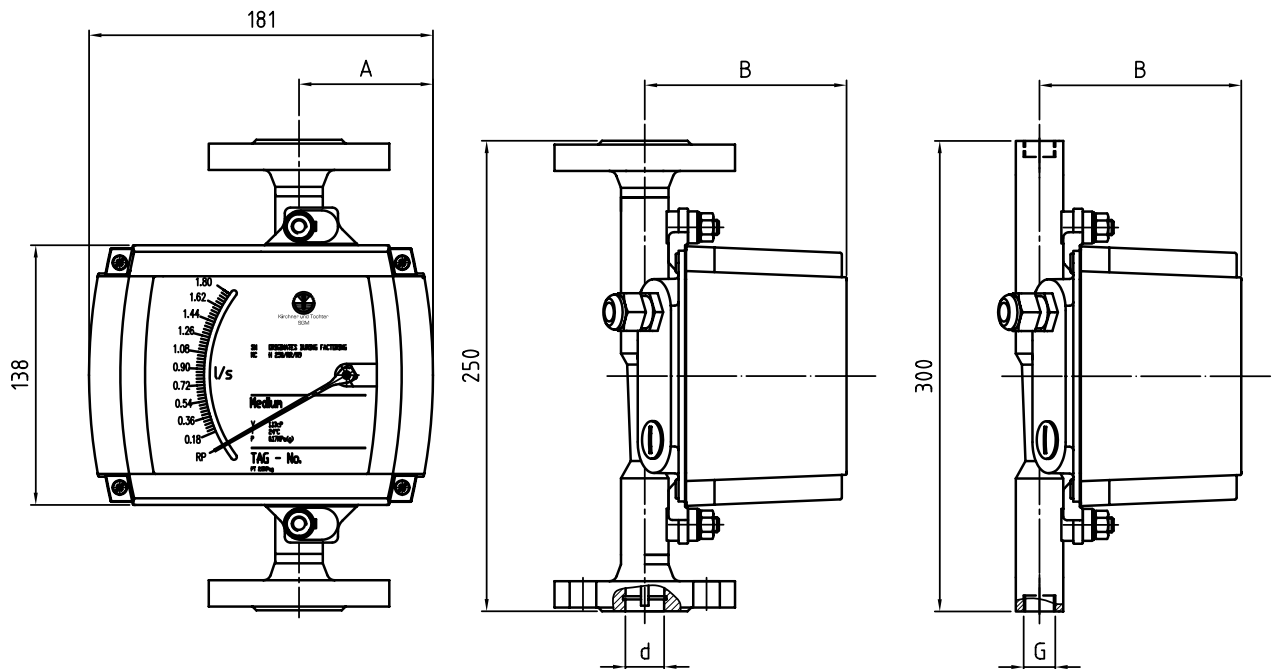

## Dimensions and weights

### (Design: stainless steel with flanged)

DN	PN	Dimensions				Ø d	Weight kgs	
		L	A	B	DIN flanges		with heating	
15	40	250	70,5	107	20	3,5	4,8	
25	40	250	70,5	119	32	5,0	6,7	
50	40	250	57,5	132	65	8,2	10,4	
80	16	250	57,5	148	89	12,2	14,0	
100	16	250	57,5	158	114	14,0	16,6	

Overall length for devices with internal thread to ISO 228: 300 mm, to ANSI B 16.5 (3" / 300 lbs and higher): 300 mm

### (Design: ceramic/PTFE with flanged connection)

DN	PN	Dimensions				Ø d	Weight kgs DIN flanges	
		L	A	B				
15	40	250	70,5	107	20	3,5		
25	40	250	70,5	119	32	5,0		
50	40	250	57,5	132	65	10,0		
80	16	250	57,5	148	89	13,0		
100 <sup>1)</sup>	16	250	57,5	158	114	15,0		

<sup>1)</sup> PTFE only

Overall length for devices with internal thread to ISO 228: 300 mm, to ANSI B 16.5 (3" / 300 lbs and higher): 300 mm

### (Design: stainless steel with internal thread)

DN	G	Dimensions				Ø d	Weight kgs	
		L	A	B				
15	G 1/2	300	70,5	107	20	3,5		
15	1/2" NPT	300	70,5	107	20	3,5		
15	3/4" NPT	300	70,5	107	20	3,5		
15	G 1	300	70,5	107	20	3,5		
25	G 1	300	70,5	119	32	5,0		
25	1" NPT	300	70,5	119	32	5,0		



# Variable area flow meters

## Measuring ranges (stainless steel design)

Size	Stainless steel float		Air m <sup>3</sup> /h at STP <sup>1)</sup>	Pressure loss mbar
	Water l/h	Pressure loss mbar		
15 or 1/2"	2,5 – 25	26	0,065 – 0,65	21
	4,0 – 40	26	0,1 – 1	21
	6,3 – 63	26	0,15 – 1,5	21
	10 – 100	26	0,22 – 2,2	21
	16 – 160	26	0,36 – 3,6	21
	25 – 250	26	0,55 – 5,5	21
	40 – 400	28	1,0 – 10	21
	63 – 630	32	1,4 – 14	22
25 or 1"	100 – 1000	50	1,8 – 18	38
			2,8 – 28	50
	63 – 630	32	1,4 – 14	24
	100 – 1000	33	2,2 – 22	24
	160 – 1600	34	3,5 – 35	25
	250 – 2500	38	5,0 – 50	26
50 or 2"	400 – 4000	45	8,0 – 80	30
	630 – 6300	103 <sup>2)</sup>	11,0 – 110	78
			17,0 – 170	103 <sup>2)</sup>
	630 – 6300	74	8,0 – 80	13
	1000 – 10000	77	11,0 – 110	13
80 or 3"	1600 – 16000	84	15,0 – 150	13
	2500 – 25000	104	23,0 – 230	60
			35,0 – 350	69
			60,0 – 600	104
100 or 4"	2500 – 25000	68	35,0 – 350	16
	4000 – 40000	89	40,0 – 400	16
100 or 4"	6300 – 63000	120		
	10000 – 100000	220		

Float damping system recommended for devices used for gas flow measurement!

<sup>1)</sup> at STP (0°C and 1.013 bar abs.)

<sup>2)</sup> 300mbar with damping

## Measuring ranges (PTFE/ceramic design)

Size	PTFE float		Ceramic float		Air m <sup>3</sup> /h at STP <sup>1)</sup>	Pressure loss mbar
	Water l/h	Pressure loss mbar	Water l/h	Pressure loss mbar		
15 or 1/2"	2,5 – 25	65	3 – 30	62		
	4,0 – 40	66	5 – 50	64	0,18 – 1,8	64
	6,3 – 63	66	7 – 70	66	0,24 – 2,4	66
	10 – 100	68	13 – 130	68	0,40 – 4,0	68
	16 – 160	72	20 – 200	70	0,65 – 6,5	70
	25 – 250	86	25 – 250	72	0,90 – 9,0	72
	40 – 400	111				
	25 or 1"	63 – 630	70	50 – 500	55	1,8 – 18
100 – 1000		80	70 – 700	60	2,2 – 22	60
160 – 1600		108	110 – 1100	70	3,0 – 30	70
250 – 2500		158	160 – 1600	82	5,0 – 50	82
			250 – 2500	100	7,5 – 75	100
50 or 2"	400 – 4000	81	450 – 4500	70	14 – 140	70
	630 – 6300	110	630 – 6300	80	20 – 200	80
	1000 – 10000	170	1100 – 11000	110	35 – 350	110
80 or 3"	1600 – 16000	81	1600 – 16000	70		
	2500 – 25000	95	2500 – 25000	85		
100 or 4"	4000 – 40000	100				

Float damping system recommended for devices used for gas flow measurement!

<sup>1)</sup> at STP (0°C and 1.013 bar abs.)



## Options

### EM Electrical transmitter two-wire technology

The EM electrical signal output can be built into the indicator part.

A load-independent current of 4 to 20 mA in 2-wire connection is supplied that is proportional to the instantaneous flow rate. Provided it has an intrinsically safe power supply, the transmitter can also be used in hazardous areas.

Product data and measuring range are easily retrieved with the help of HART<sup>a</sup> communication.

Power supply	24 V DC
Current consumption	4 to 20,4 mA for 0% to 102.5% of the measured value
Namur failure signal	> 20,8 mA
Reproducibility	< 0,1% of FS
Linearity error	< 0,1%
Influence of supply power	< 0,1%
Ext. resistance dependence	< 0,1%
Temperature effect	< 5µA / K
Max. load impedance	0 (250) to 800 Ω
Individual certificate	PTB 00 ATEX 2063

\* With HART<sup>®</sup> communication, this value is the minimum value

For use in hazardous areas: built-in equipment may only be connected to separate intrinsically safe circuits.

### EMZ electrical transmitter with totalizer

The EMZ flow totalizer in 3-wire technology can be installed together with the EM electrical current output.

A 6-digit LED display indicates the total flow value and can be switched over to indicate the instantaneous flow rate in 0...100%.

A galvanically separated pulse output supplies a pulse on each totalizer advance indicated.

Data save is automatic in the event of voltage drop!

The EMZ flow counter is not suitable for use in hazardous areas!

If an indicator with totalizing function is required in the hazardous zone, this must be of special design - a digital display unit in flameproof enclosure "Ex d". The cable entry gland (to be provided by customer) must accordingly also be of flameproof design.

Supply power	16...30 V DC
Ext. current loop	0...600 Ω
Power consumption	max. 2 Watt
Power supply, pulse out	10...30 V DC
Max. current	50 mA
Max. power loss	250 mW
T on	fixed pulse width 80 ms
T off	dependent on flow rate
U on	U <sub>b</sub> - 3 V
U off	0 V
Pulse value	1 puls = 1 flow unit (1 litre, 1 m <sup>3</sup> , ...)
Ambient temperature	- 25°C bis + 65°C
Indication error	< 1% of value indicated, max. one display unit

## Limit switch

Up to two inductive switches can be built into the indicator part.

The inductive contact switches (hysteresis-free) when the contact vane dips into the slot-type initiator. The setting pointer trips when the limit value is over- or undershot.

## Switch types:

SC3,5-N0-Y                      2-wire technology (NAMUR)  
SB3,5-E2                         3-wire technology (Non Ex)

<b>2-wire</b>	
SC3,5-N0-Y	
Switching element function	NAMUR NC contact
Nominal voltage U <sub>0</sub>	8 V
Current consumption:	
Pointer vane not sensed	≥ 3 mA
Pointer vane sensed	≤ 1 mA
Ambient temperature	- 25°C to + 100°C
EMV according to	NE21
SIL according to	IEC 61508
Approval certificate	PTB 99 ATEX 2219X only with isolation switching amplifier
<b>3-wire</b>	
SB3,5-E2	
Switching element function	PNP NO contact
Nominal voltage U <sub>0</sub>	10...30 V
Current consumption:	
Pointer vane not sensed	≤ 0,3 V
Pointer vane sensed	U <sub>b</sub> - 3 V
Ambient temperature	- 25°C to + 70°C
Continuous current	max. 100 mA
No-load current I <sub>0</sub>	≤ 15 mA
EMV according to	EN 60947-5-2

Degree of protection (EN 60529 / IEC 529) IP 67, NEMA 6



## Variable area flow meters

# SGM

### Safety directions

**Do not operate devices beyond the specified allowable operating pressure and the allowable operating temperature.**

**Avoid pressure surges.**

### Conformity with EC Directives

**The SGM variable area flow meter meets all requirements of EC Directives applicable to the product.**

- EMV Directive (89/336/EWG)  
EN 61326 : 03/1997  
+A1 : 04/1998  
+A2 : 03/2001
- ATEX (94/9/EG)  
EN 50014:1997 +A1 +A2  
EN 50020:1994
- DGRL (97/23/EG)

The KIRCHNER equipment has been tested in compliance with the applicable CE-regulations of the European Community.

The respective declaration of conformity is available on request.

The KIRCHNER QM-System will be certified in accordance with DIN-EN-ISO 9001:2000.

The quality is systematically adapted to the continuously increasing demands.



## Kirchner und Tochter

A. Kirchner & Tochter GmbH Dieselstraße 17 · D-47228 Duisburg  
Fon: +49 2065 9609-0 · Fax: +49 2065 9609-22 Internet: [www.kt-web.de](http://www.kt-web.de) · e-mail: [info@kt-web.de](mailto:info@kt-web.de)