

Sprinkler measuring orifice

SMB



Assembly and operating instructions

Sprinkler measuring orifice SMB/SMB-OE



Kirchner und Tochter

A. Kirchner & Tochter GmbH Dieselstraße 17 · D-47228 Duisburg
Fon: +49 2065 9609-0 · Fax: +49 2065 9609-22 Internet: www.kt-web.de · e-mail: info@kt-web.de
Version 2.5

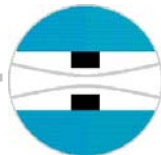

- 1. General 3
- 1.1 Exclusion of liability 3
- 2. Safety 4
- 2.1 General safety information 4
- 2.2 Proper use 4
- 2.3 Explanation of pictographs and signs 4
- 2.4 Safety information for the owner and the operators 5
- 2.5 Regulations and guidelines 5
- 2.6 VdS approval 5
- 3. Transport and storage 6
- 4. Description 7
- 4.1 Field of application 8
- 4.2 Design and function 8
- 4.3 Peculiarity SMB-OE 8
- 4.4 Installation variants 9
- 5. Installation 10
- 5.1 Preparation for installation 10
- 5.2 Installation of the orifice ring 11
- 5.3 Installation of the dial gauge 12
- 5.4 Minimesse hose connection 14
- 6. Commissioning 15
- 6.1 Zero-point adjustment 15
- 6.2 Initial startup 16
- 7. Maintenance 17
- 8. Service 17
- 9. Disposal 17
- 10. Technical data 18
- 10.1 General technical data 18
- 10.2 Materials 18
- 10.3 Measuring range 19
- 10.4 Inlet and outlet paths 20
- 10.5 Dimensions 21
- 10.6 Installation kits 22
- 11. Spare parts 23



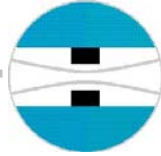

1. General

These assembly and operating instructions apply to sprinkler measuring orifices, type SMB with a display of m^3/min and to the SMB-OE with percentage display.

All information contained in these operating instructions on assembly, operation, repairs and maintenance have to be observed and adhered to.

The operating instructions form an integral part of the sprinkler measuring orifice; they have to be kept at a suitable location in the vicinity of the place of application and must be accessible for the operators.

In case of interaction of different plant components, the operating instructions of those also have to be observed.

1.1 Exclusion of liability

Kirchner und Tochter will not accept any liability for damage or disruptions caused by operating errors, non-observance of these assembly and operating instructions, inexpert execution of assembly and repair work or by the improper use of the sprinkler measuring orifice.



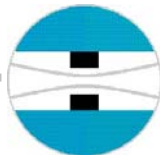

2. Safety

2.1 General safety information

These assembly and operating instructions contain important information to be observed on the assembly, the operation, on repairs and maintenance of the sprinkler measuring orifice. Each person charged with the assembly, the operation, repairs and maintenance must have read and understood these operation instructions.

Non-observance of these assembly and operating instructions, or inexpertly conducted assembly and repair work may result in disruptions of the sprinkler system. As a consequence, man or animal may be at risk or material assets may be damaged.

Hazards by electric energy or released media energy must be prevented.

2.2 Proper use

The VdS approval of the sprinkler measuring orifice is valid for the flow measurement of water. Installation in pipework may be effected only between two flanges (intermediate flange assembly).

Select the sprinkler measuring orifice model in accordance with the pipe cross-section at the location of application for the sprinkler measuring orifice.

The limit values of the sprinkler measuring orifice are to be observed as prescribed in chapter „Technical data“. Rebuilding or other modifications of the measuring device may be effected by Kirchner und Tochter only.

2.3 Explanation of pictographs and signs



Pictograph on work safety

This pictograph can be found at all hints on work safety in these assembly and operating instructions pointing out hazards for life and limb of persons.

Further, this pictograph highlights safety hints in these operating instructions that point to regulations, guidelines or operating sequences that must be observed without fail. Non-observance may result in damages to or a destruction of the measuring orifice and/or other parts of the installation.



Kirchner und Tochter

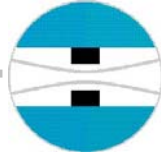

2.4 Safety information for the owner and the operators

The personnel charged with the assembly, the operation, repairs and maintenance must be qualified to fulfill the respective tasks and must have been trained and instructed with regards to the task in question.

2.5 Regulations and guidelines

Apart from the information contained in these assembly and operating instructions, the regulations, guidelines and standards such as DIN EN, as well as the DVGW and VdS guidelines in case of branch-oriented applications must be observed; the same is true for the regulations on the prevention of accidents valid in the destination country.

2.6 VdS approval

The sprinkler measuring orifice has been approved by the VdS. During the installation, operation, repairs and maintenance, the VdS guidelines have to be adhered to.



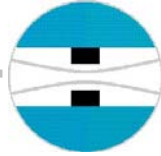

3. Transport and storage

At the factory, the sprinkler measuring orifice was suitably packed for transport and storage. Transport and storage should be effected while in the original packing only.

The measuring device is to be protected against shocks and blows!



Kirchner und Tochter

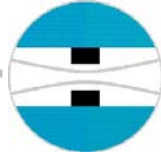

4. Description

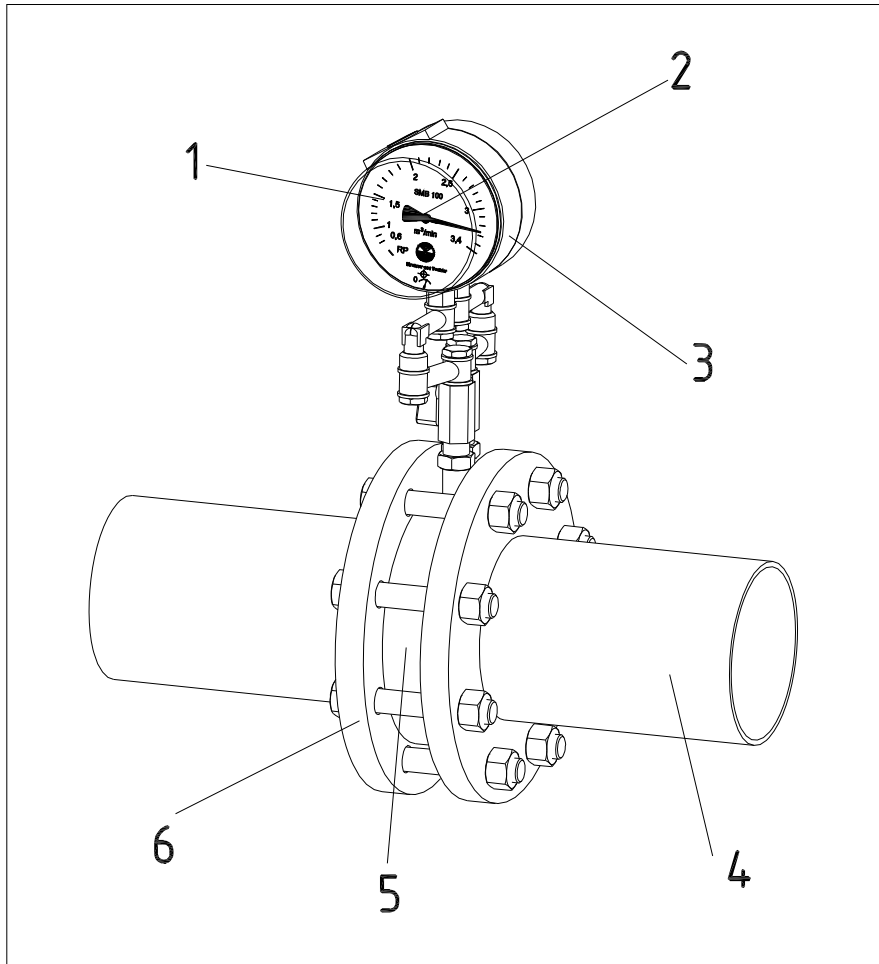

Pic. 1

- 1. scaling
- 2. hand
- 3. dial gauge
- 4. pipe work
- 5. orifice
- 6. flange



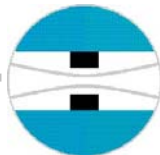

4.1 Field of application

The sprinkler measuring orifice SMB is a measuring device employed to measure the flow rate in pipework of stationary sprinkler systems.

4.2 Design and function

Due to physical reasons, different pressure potentials are found on both sides of the orifice [5]. This differential pressure acts quadratic proportional to the volume flow inside the pipework [4].

The scaling [1] of the dial gauge [3] is realized in volume flow units (m^3/min). The dial gauge displays the present volume flow inside the pipe via the position of the hand [2].

4.3 Peculiarity SMB-OE

All information contained in these assembly and operating instructions are also valid for the measuring device SMB-OE.

A peculiarity of the sprinkler measuring orifice SMB-OE is the fact that the scaling of the scale reading plate has been subdivided in percent.

A label on the dial gauge serves to read the effective flow values in m^3/min for the individual nominal cross-section of the pipe. (refer to chapter 10.3)

This permits the combination of the dial gauge with all nominal cross-sections of the SMB-OE.



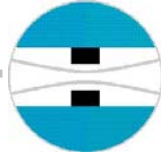

4.4 Installation variants

Installation direction of flow

from left to right

from right to left

from bottom to top

from top to bottom

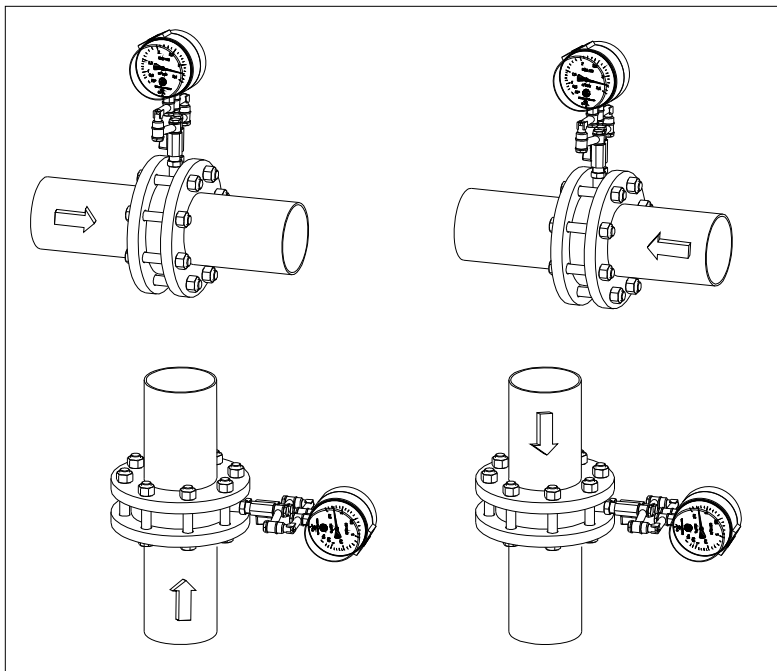

Pic. 2

Thanks to the special articulated design, the dial gauge of the sprinkler measuring orifice pivots by 180 degrees in both directions. Therefore, an assembly in various installation positions is possible (refer to picture 2).



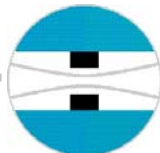

5. Installation



Installation may be effected by trained personnel only!

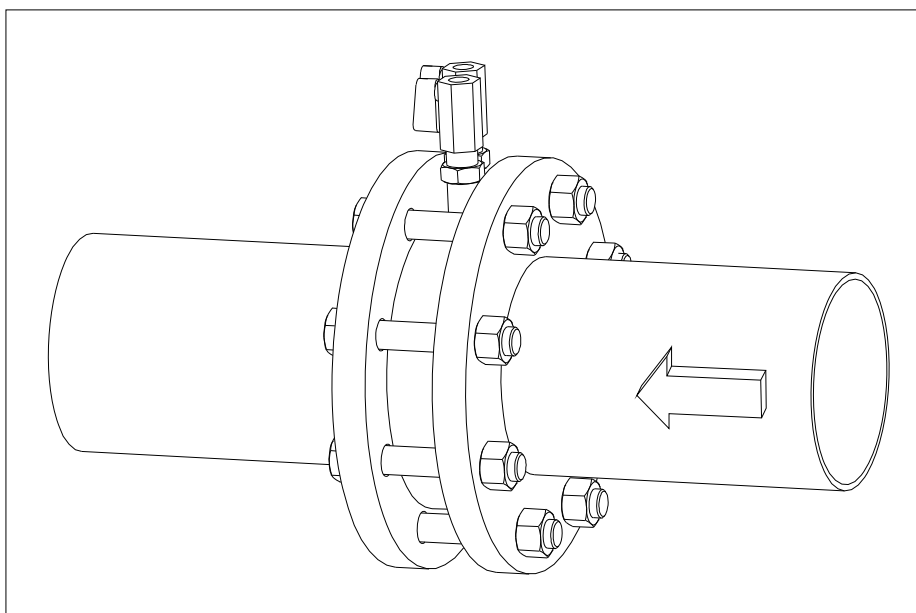

Pic. 3

5.1 Preparation for installation

1. Verify the local conditions and the direction of flow inside the pipework at the place of installation of the sprinkler measuring orifice.
2. Make sure that the sprinkler measuring orifice is suitable for installation at the planned location with regards to nominal cross-section, min. inlet and outlet distance, maximum working pressure and medium (also refer to chapter 10).
3. Shut off and secure the pipework in accordance with regulations and empty the circuit.
4. Lay out the installation kit for the delivered measuring orifice (refer to chapter 10.6).



Kirchner und Tochter

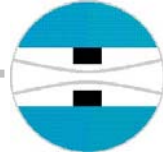

5.2 Installation of the orifice ring

For an intermediate flange installation of the sprinkler measuring orifice, two flanges PN 16 have to be installed in accordance with DIN EN 1092-1 and the VdS guidelines. The flange distance required for installation is 40 mm with an additional 2 mm each for both flange seals.

1. Pre-assemble the flanged connection in such a way as to permit the insertion of the measuring orifice with its seals from the front (vertical piping) or from above (horizontal piping), respectively.
2. Together with the seals attached on both sides, place the measuring orifice between both prepared flanges and slide same all the way against the pre-assembled screws.

This serves to center orifice and seal. The seals have to be in true alignment with the entire circumference of the measuring orifice.

The flow direction has to coincide with the hand on the measuring orifice.

3. Insert the remaining screws and uniformly tighten all screwed connections crosswise.

Note

The best measuring accuracy is obtained with smooth inside pipe joints and pipe configurations in accordance with the VdS guidelines.



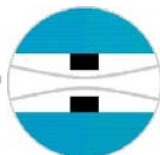

5.3 Installation of the dial gauge

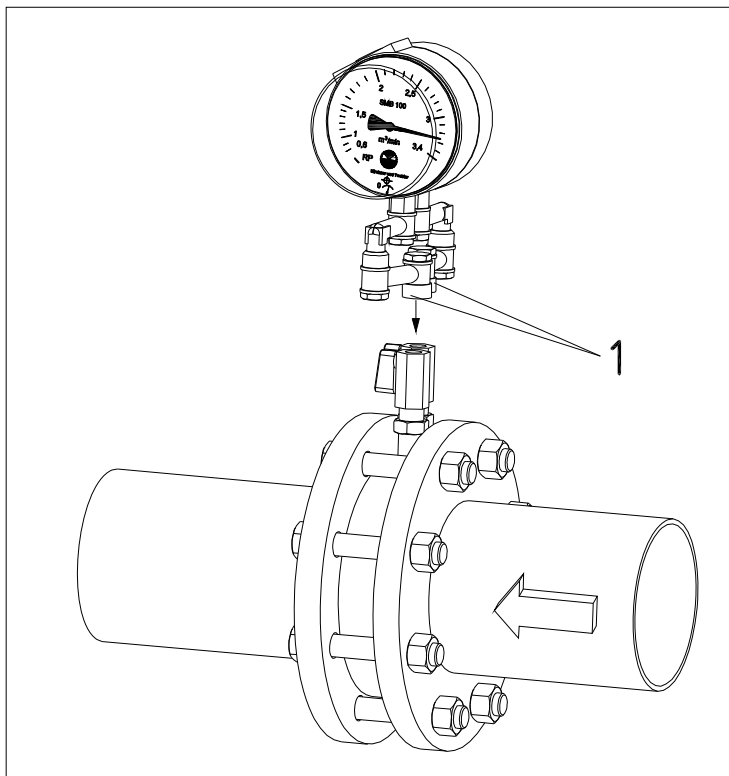

Pic. 4

Remove the shipping protection plugs [1, Pic. 4] from the threads of the dial gauge and the screwed connections of the measuring orifice.



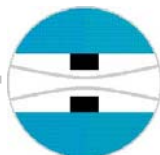

SMB

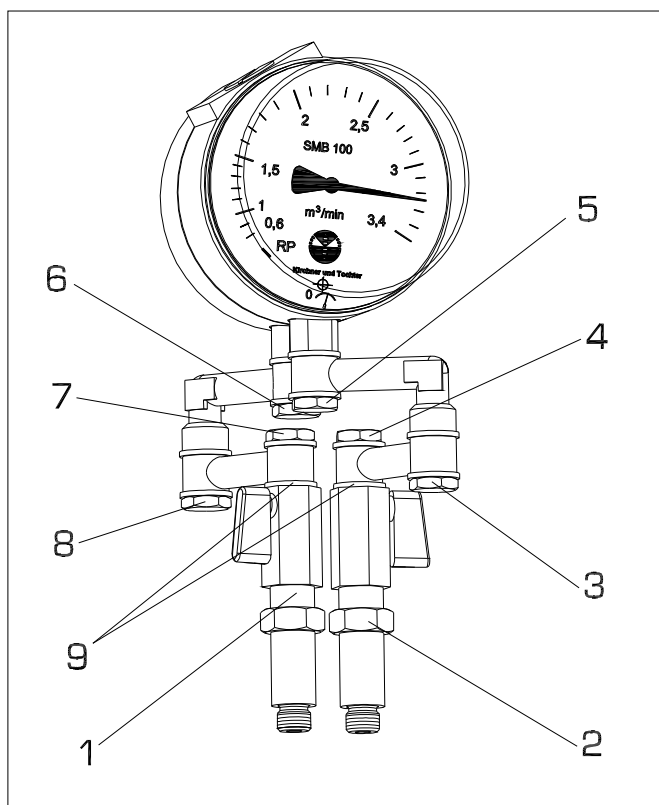

Pic. 5

The sealing rings [9] required during assembly have been attached to the dial gauge with cable binders.

1. Use screws [4 and 7] to fix the dial gauge with its inserted sealing rings [9] to the ball valves of the measuring orifice.

In the process, connect the plus line of the dial gauge with the plus line of the measuring orifice and minus line of the dial gauge with the minus line of the measuring orifice.

Observe the respective markings at the dial gauge and on the label of measuring orifice.

2. Position the dial gauge in such a way, as to permit an unimpeded reading of the display.
3. Tighten the fixing screws [4 to 7] with a torque of 15 Nm.
In order to prevent leaks, the joining pieces [1 and 2] should not be tightened with a torque.
When tightening the screwed connections [4 and 7] immobilize the joining pieces [1 and 2] with a wrench.
4. Next follow the steps in chapter 6 „Commissioning“.



Kirchner und Tochter

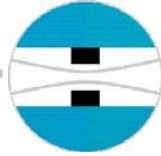

5.4 Minimesse hose connection

Scope of delivery

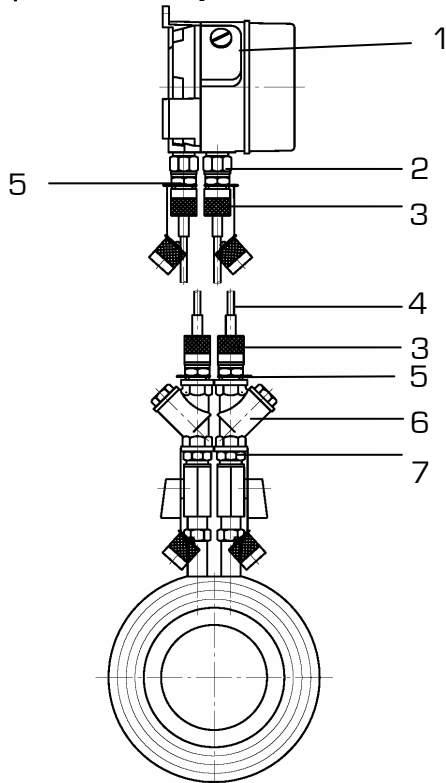

With assembly of the Minimesse hose connection the hinge threading needs not to be applied.

The Minimesse hose connection is delivered already partly assembled.

To the Minimesse scope of delivery belong:

1. indicator part with fastening brackets for wall mounting.
2. 1/4" i/a double threaded nipple
3. 1/4" a threaded fitting
4. hose connection (l = 1500 mm)
5. sealing ring
6. strainer
7. 1/4" a/a detachable double threaded nipple

Pic. 5a

Assembly

The hose end with the strainer will be mounted at the orifice side. The hose end without strainer will be mounted at the indicator part.

The indicator part (with fastening brackets for wall mounting) can be installed by the customer in a location that is vibration-free. As a rule, these are concrete buttresses. Before start-up, vent the hose lines up to a point directly in front of the indicator part.

Notes on operation:

To ensure serviceability of hoses and so as not to shorten their useful life by exposing them to additional stresses, be aware of the following:

- When in use, hose lines should never be subjected to tensile, torsional or compressive stresses.
- Avoid damage through external mechanical, thermal or chemical influence.
- Do not paint over hose lines.



Kirchner und Tochter

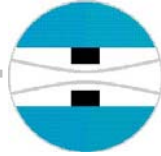

6. Commissioning

6.1 Zero-point adjustment

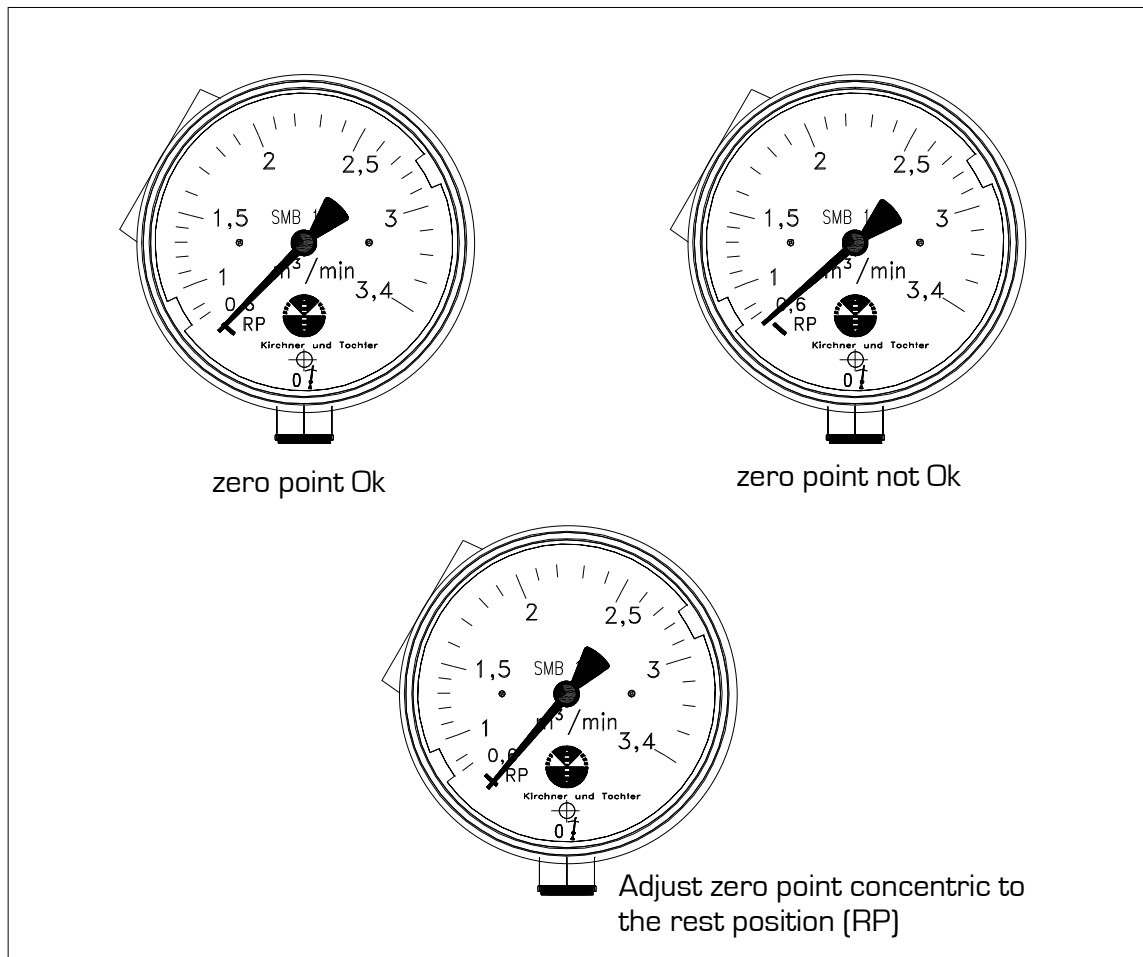

Pic. 6

In case the hand of the dial gauge is not within the range of the rest position marked RP with the flow cut off, the sprinkler measuring orifice has to be readjusted as follows:

1. Detach the screws (Pic 7, 3) from the dial gauge
2. Remove the translucent cover lid
3. With the zero-point adjustment screw [4] adjust the hand to the center of the rest position (Pic. 6)
4. Put cover lid back on
5. Insert screws and tighten same



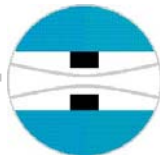

6.2 Initial startup

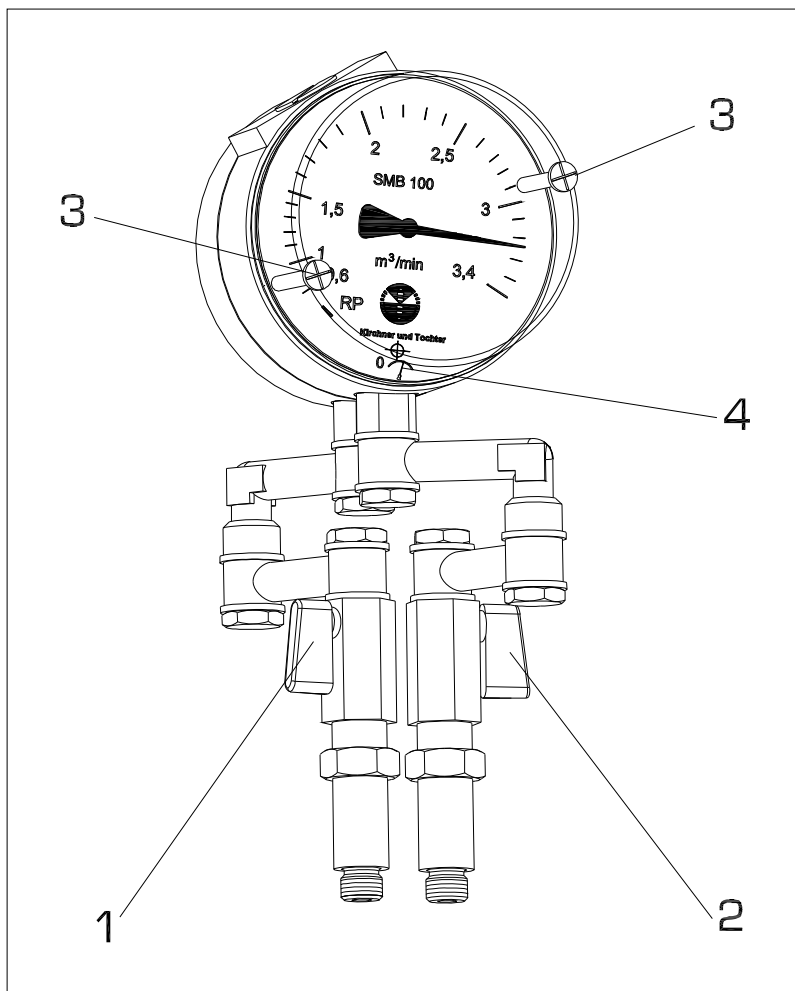

Pic. 7

The correct installation is a prerequisite for commissioning.

The following steps have to be followed for the initial startup:

1. Close ball valves [1 and 2]
2. Put conduit under pressure
3. Simultaneously open the ball valves [1 and 2]
4. Check tightness of all components of the sprinkler measuring orifice.



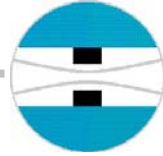

7. Maintenance

The sprinkler measuring orifice is maintenance-free. In order to warrant a reliable operation and a long service life of the device, we recommend regular checks of the device, such as:

- check of the display
- remove deposits inside the nozzles of the banjo bolts
- check of the joints between orifice ring and dial gauge
- If Minimesh hose connection is employed: check filter in strainer regularly.

The exact checking cycles are determined by the VdS regulations and are to be adjusted depending on the operating and surrounding conditions.

8. Service

All defective or faulty devices are to be returned directly to our repair shop.

In order to process complaints of our customers as quickly as possible, kindly contact our Sales Department tel. no. +49 2065-96090 before returning any parts.

9. Disposal

For a better environment:

Please help us protect our environment by disposing of the parts used in accordance with the relevant legislation or by recycling same.



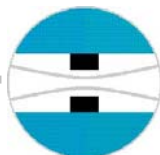

10. Technical data

10.1 General technical data

VdS approval	G 4990049
Measuring principle	Differential pressure metering at orifice
Scale	in m ³ /min or % at SMB-OE
max. working pressure	16 bar
Installation	intermediate flange installation in accordance with the VdS guidelines
Measuring accuracy	2,5% at the approved full scale range value 5,0% at the approved measuring range start value The inter-values for the permitted measuring accuracy are the result by a linear interpolation.

10.2 Materials

Orifice	hard-coated aluminum
Screwed connections	nickel-plated brass, 1.4308
Ball valves	nickel-plated brass
Dial gauge	Aluminum



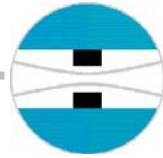

10.3 Measuring range

Measuring range SMB

Model	For pipes with inner diameter of [mm]/[DN]	Approved measuring range [m ³ /min]	Max. deviation from the full-scale range [m ³ /min] [%]
SMB 80	83,1 / 80	0,6 - 2,1	± 0,0525 ±2,5
SMB 100	107,9 / 100	1 - 3,4	± 0,085 ±2,5
SMB 150	160,3 / 150	2 - 7,25	± 0,18125 ±2,5
SMB 200	210,1 / 200	4 - 12,35	± 0,30875 ±2,5
SMB 250	263,0 / 250	4 - 18,12	± 0,453 ±2,5

Measuring range SMB-OE

DN80 Indication		DN100 Indication		DN150 Indication	
%	[m ³ /min]	%	[m ³ /min]	%	[m ³ /min]
100,00	2,10	100,00	3,40	100,00	7,25
90,00	1,89	90,00	3,06	90,00	6,53
80,00	1,68	80,00	2,72	80,00	5,80
70,00	1,47	70,00	2,38	70,00	5,08
60,00	1,26	60,00	2,04	60,00	4,35
50,00	1,05	50,00	1,70	50,00	3,63
40,00	0,84	40,00	1,36	40,00	2,90
30,00	0,63	30,00	1,02	30,00	2,18
28,57	0,60	29,41	1,00	27,59	2,00

DN200 Indication		DN250 Indication	
%	[m ³ /min]	%	[m ³ /min]
100,00	12,35	100,00	18,12
90,00	11,12	90,00	16,31
80,00	9,88	80,00	14,50
70,00	8,65	70,00	12,68
60,00	7,41	60,00	10,87
50,00	6,18	50,00	9,06
40,00	4,94	40,00	7,25
30,00	3,71	30,00	5,44
32,39	4,00	22,08	4,00



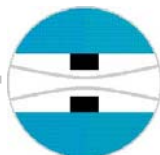

10.4 Inlet and outlet paths

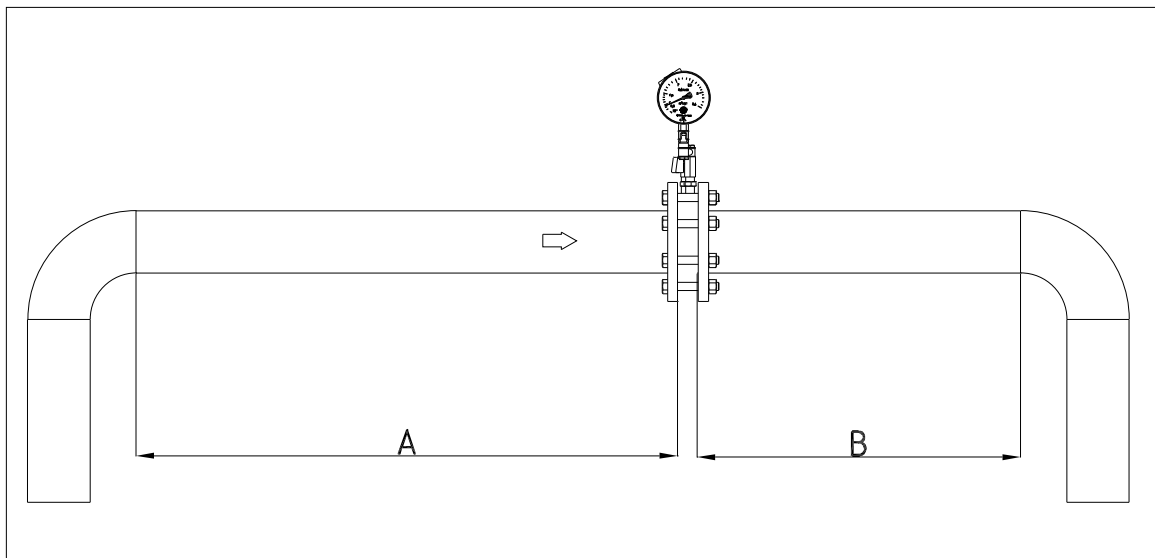

Pic. 8

The optimum accuracy is obtained, if the pipe configuration conforms to the VdS guidelines. The following inlet and outlet sections that must not contain any valves, knees, elbows, changes in cross-section or similar, apply to the various SMB models.

When using pumps creating fluctuations in the volume flow (possible with centrifugal pumps driven by a diesel engine), we recommend to extend the inlet region of steady flow from 10 d to 18 d.

Should pulsation and vibration from pumps cause unsteady indicator readings, a separate Minimesse hose connection (l = 1,500 mm) can be fitted to an indicator part that is designed for wall mounting, see Item 5.4.

Model	Min. inlet region of steady flow A [mm]	Min. outlet region of steady flow B [mm]
SMB 80	800	400
SMB 100	1000	500
SMB 150	1500	750
SMB 200	2000	1000
SMB 250	2500	1250



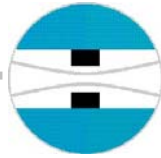

10.5 Dimensions

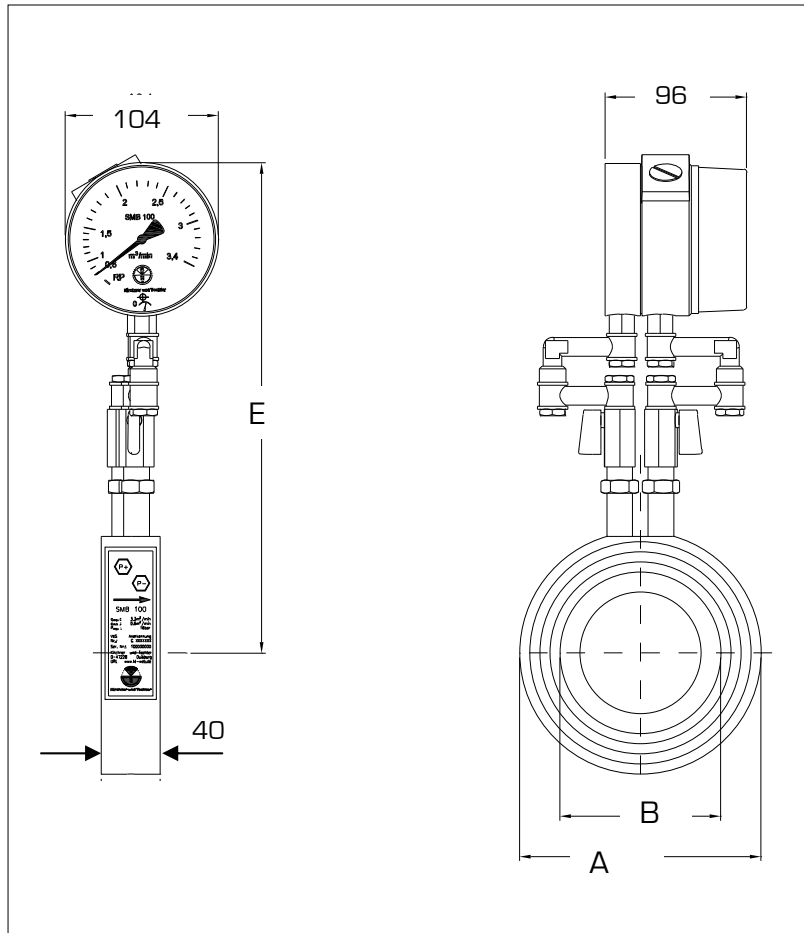

Pic. 9

Model	A [mm]	B [mm]	E [mm]
SMB 80	144	84,1	311
SMB 100	164	108,9	321
SMB 150	220	161,8	349
SMB 200	275	211,1	377
SMB 250	331	264,5	406



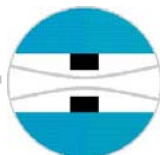

10.6 Installation kits

SMB installation kit	Quantity	Designator
DN 80	8	hexagon bolt DIN 931-M16x110-8.8 galvanized
	8	nut DIN 934-M16-8
	8	washer DIN 125-17-A2
	2	seals ¹⁾ Ø143,5x Ø86x2
DN 100	8	hexagon bolt DIN 931-M16x110-8.8 galvanized
	8	nut DIN 934-M16-8
	8	washer DIN 125-17-A2
	2	seals ¹⁾ Ø163,5x Ø111x2
DN 150	8	hexagon bolt DIN 931-M16x120-8.8 galvanized
	8	nut DIN 934-M16-8
	8	washer DIN 125-17-A2
	2	seals ¹⁾ Ø219,5xØ164x2
DN 200	12	hexagon bolt DIN 931-M20x120-8.8 galvanized
	12	nut DIN 934-M20-8
	12	washer DIN 125-21-A2
	2	seals ¹⁾ Ø274,5xØ213x2
DN 250	12	hexagon bolt DIN 931-M24x130-8.8 galvanized
	12	nut DIN 934-M24-8
	12	washer DIN 125-25-A2
	2	seals ¹⁾ Ø330,5xØ266x2

¹⁾ Use rubber seals or water-resistant seals.



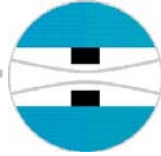

11. Spare parts

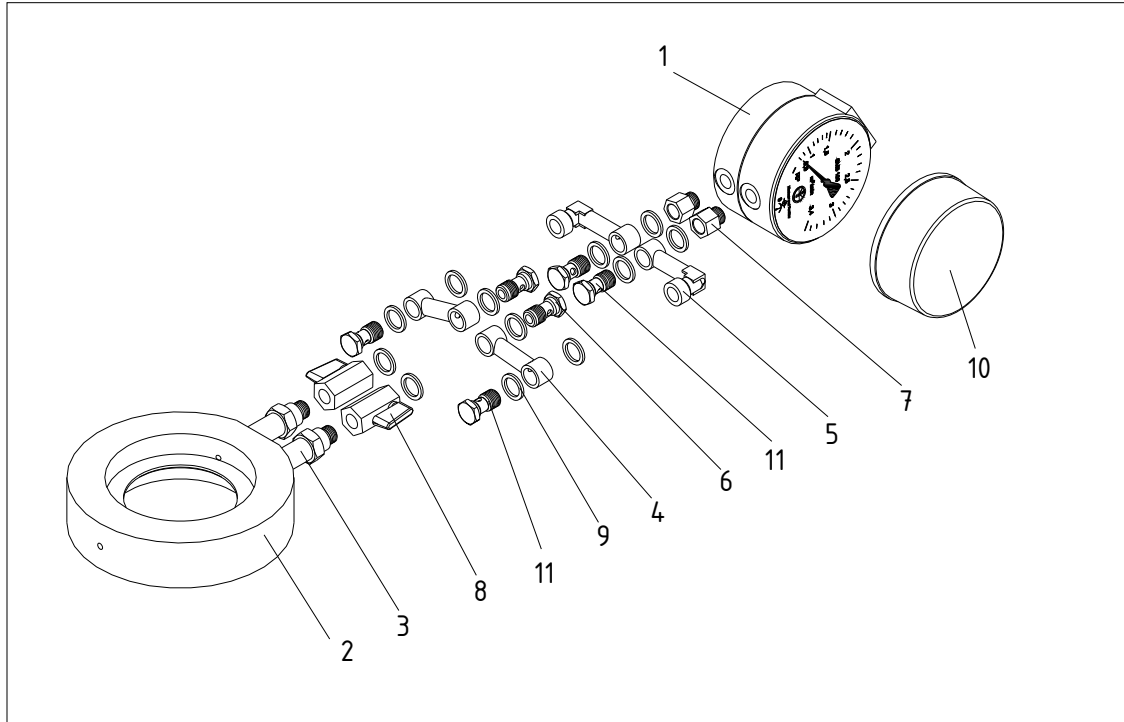

Pic. 10

Bill of parts

Pos.	Qty.	Designator	Material
1	1	Dial gauge	Al
2	1	Measuring orifice	hard-coated Al
3	2	Joining piece	CuZn nickel-plated
4	2	Straight joint	1.4308
5	2	L-type joint	1.4308
6	2	Screw	CuZn nickel-plated
7	2	Double-threaded nipple	CuZn nickel-plated
8	2	Ball valve	CuZn nickel-plated
9	12	Sealing ring	Steel, phosphatised/NBR
10	1	Clear-view cover	Acryl
11	4	Screw with damping insert	CuZn nickel-plated
12	1	Assembly and operating instructions-	--

- A) 1 orifice with joining pieces (Pos. 2, 3, 8, 9)
- B) 1 set pre-assembled fittings (Pos. 4, 5, 6, 9, 11)
- C) 1 dial gauge (Pos. 1, 7, 10)
- D) 1 set of sealing rings (Pos 9)
- E) 2 strainers for Minimes hose connections



Kirchner und Tochter

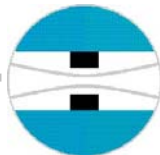

The equipment from **Kirchner und Tochter** has been tested in compliance with applicable CE-regulations of the European Community.

The respective declaration of conformity is available on request.

Technical data supplied without liability. The current valid version of our documents can be found under this URL: www.kt-web.de

The **Kirchner und Tochter** QM-System is certified in accordance with DIN-EN-ISO 9001:2008. The quality is systematically adapted to the continuously increasing demands.



Kirchner und Tochter